

Waltz (1)

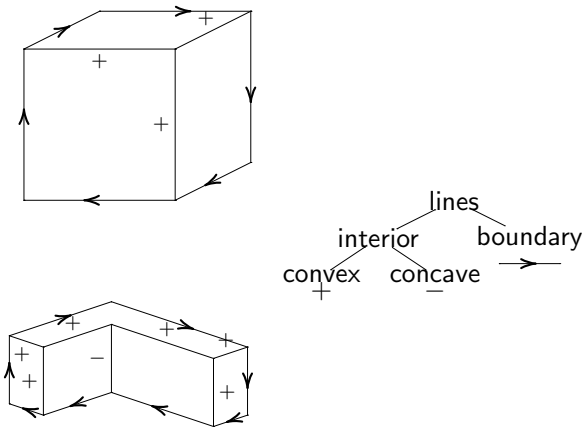

Borders: figure on the right.

Waltz (2)

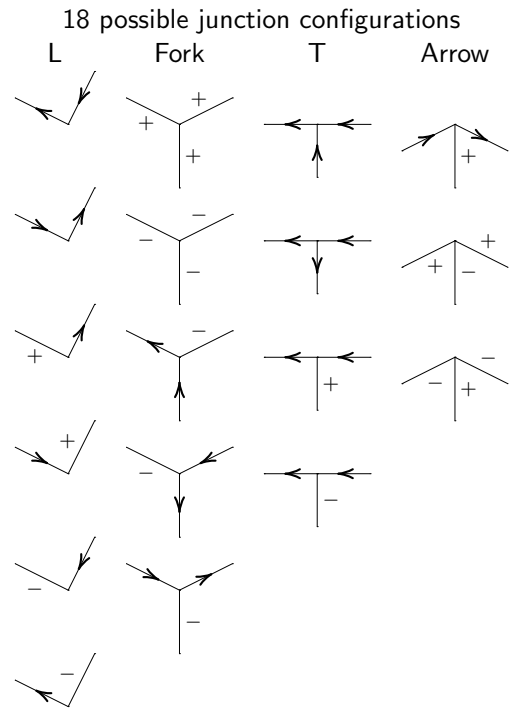

Waltz Intro (1)

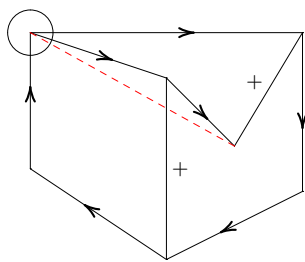

4 edges meet in one vertex

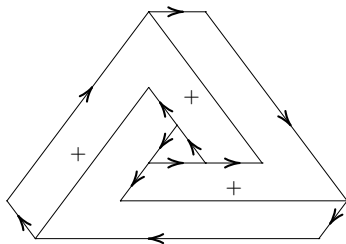

Waltz Intro (2)

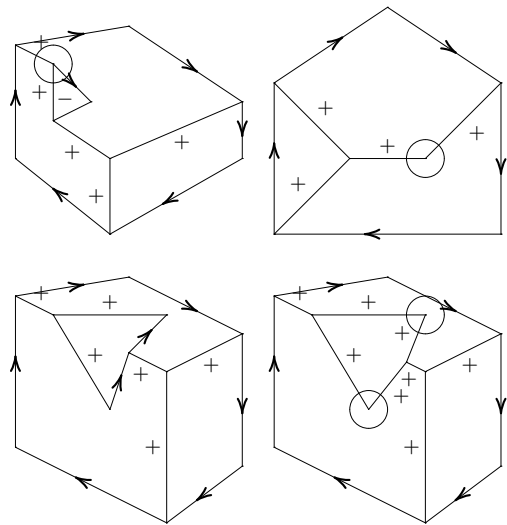

Waltz Cubes (1)

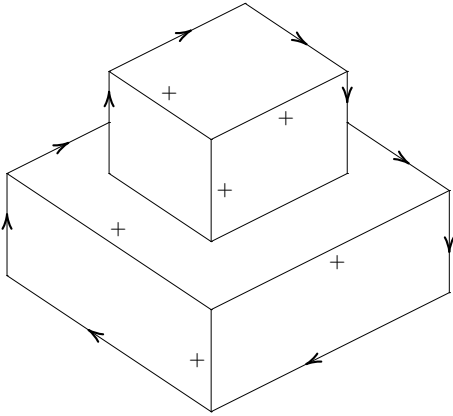

Waltz Cubes (2)



“sitting”

Waltz Cubes (3)



“floating”

Waltz Stairs (1)

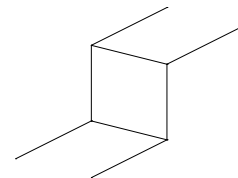

Waltz Stairs (2)

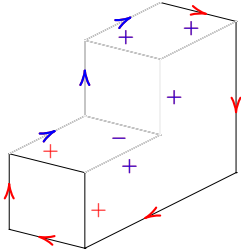

Waltz Stairs (4)

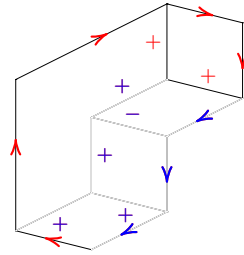

9

10

Waltz Stairs (5)

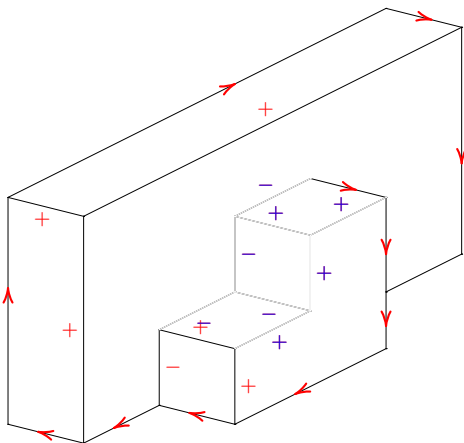

Waltz Stairs (6)

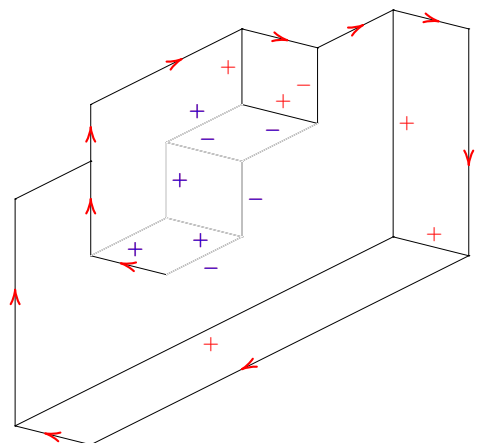

11

12

Waltz Exam (5)



Can't be made out from the figure.
6 possible solutions.

Waltz: Termination

Waltz's procedure **terminates** if
there are no more possibilities for some vertex

OR

none of the junction piles can be reduced

Waltz's procedure **does not terminate** if
no vertex has an empty pile

AND

at least one pile can be reduced

BUT

All junction piles are finite

⇒ the number of iterations is finite

⇒ Waltz's procedure **terminates**