

Exercises: Artificial Intelligence

A*

A* Search

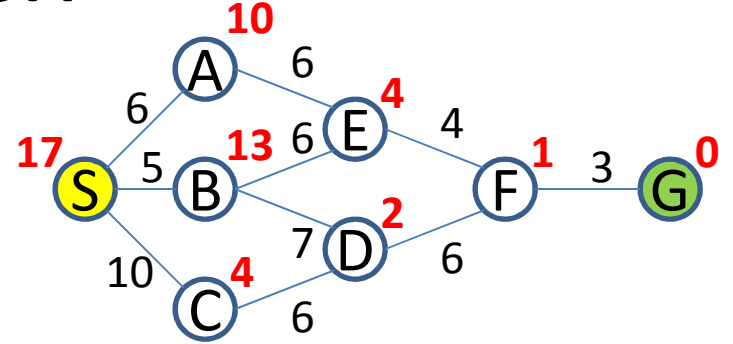

QUEUE:

S

A* Search

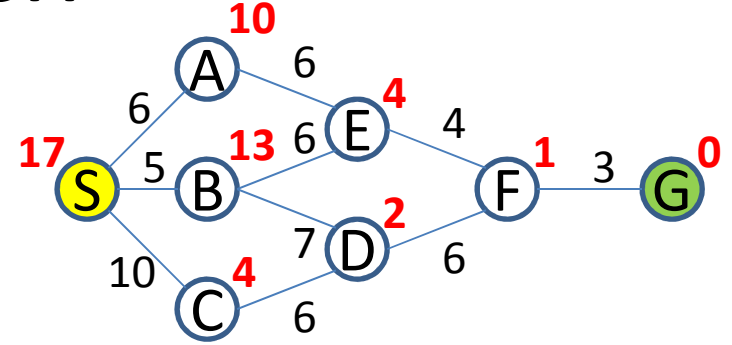
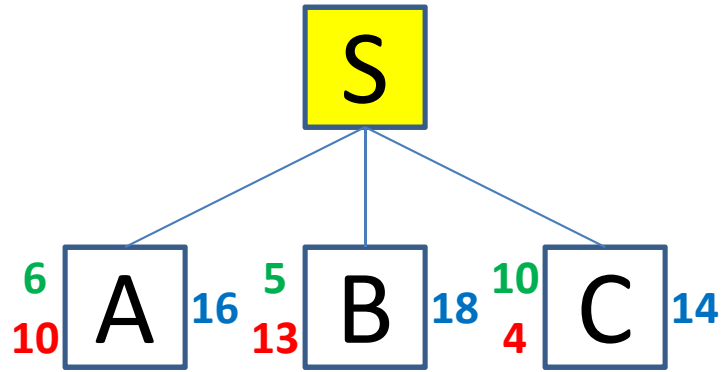

QUEUE:

SC

SA

SB

A* Search

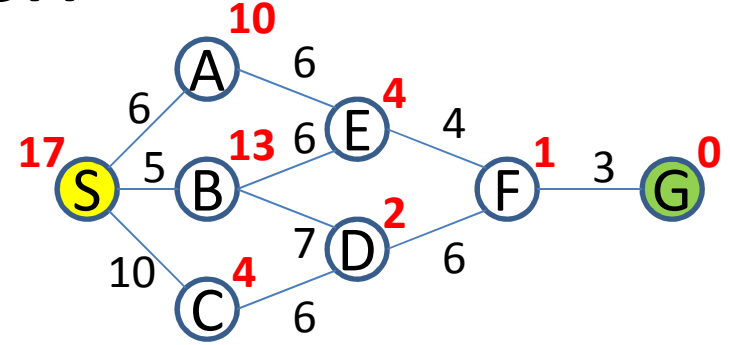
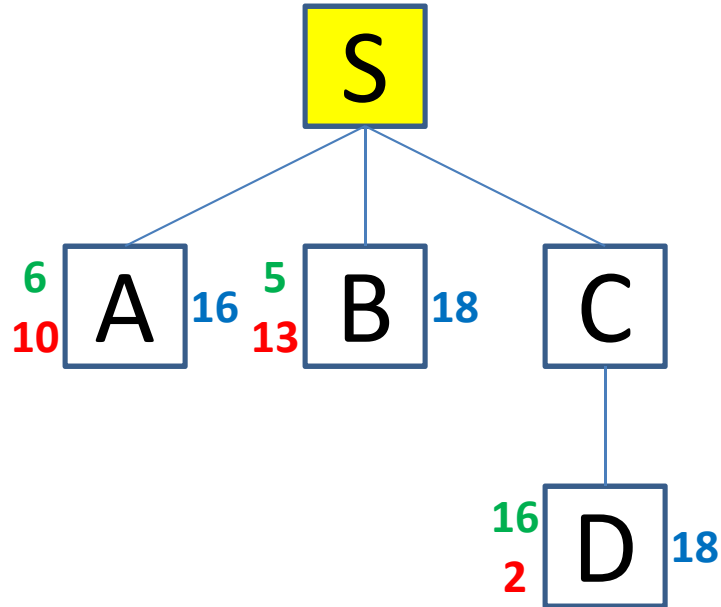

QUEUE:

SA

SCD

SB

A* Search

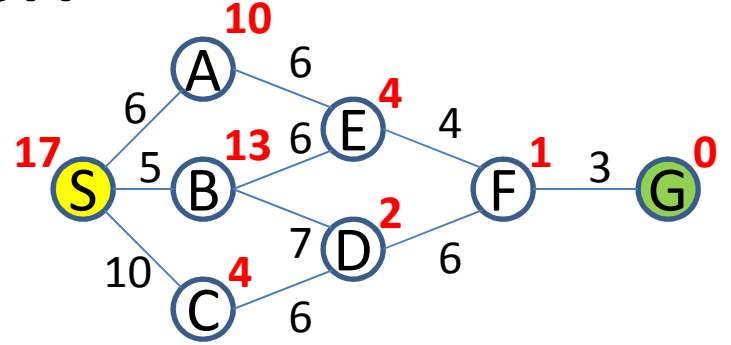
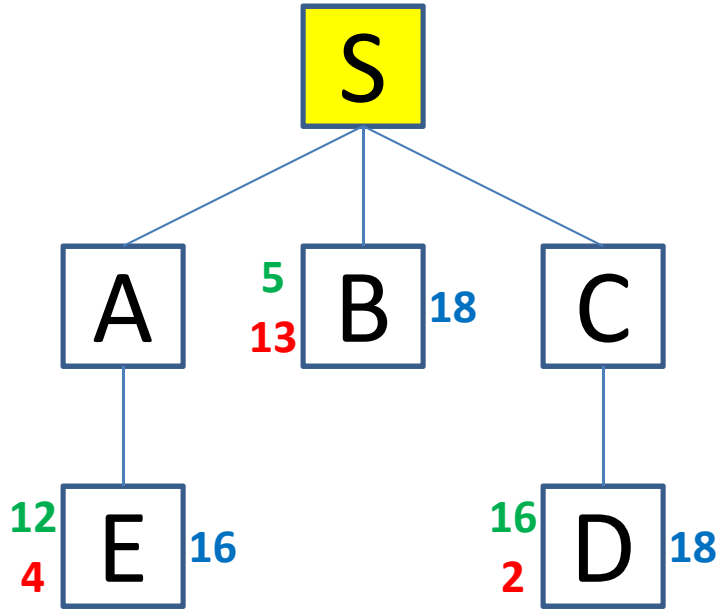

QUEUE:

SAE

SCD

SB

A* Search

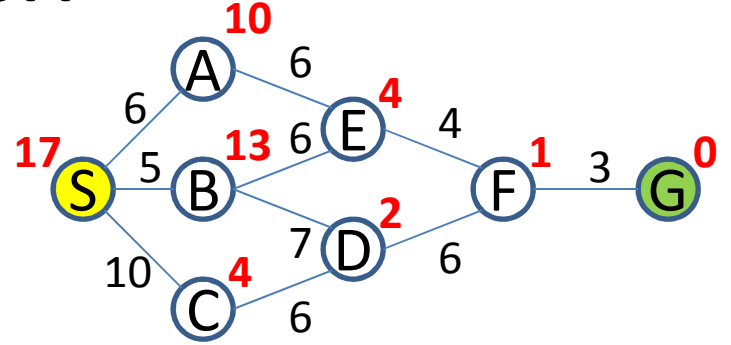
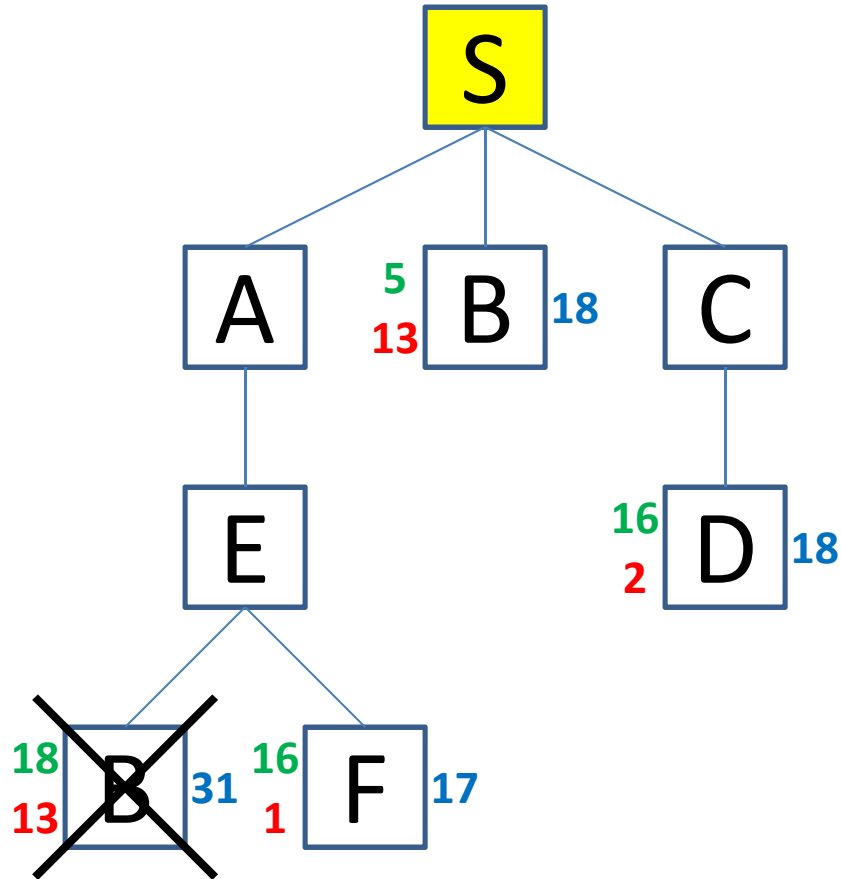

QUEUE:

SAEF

SCD

SB

SAEB

A* Search

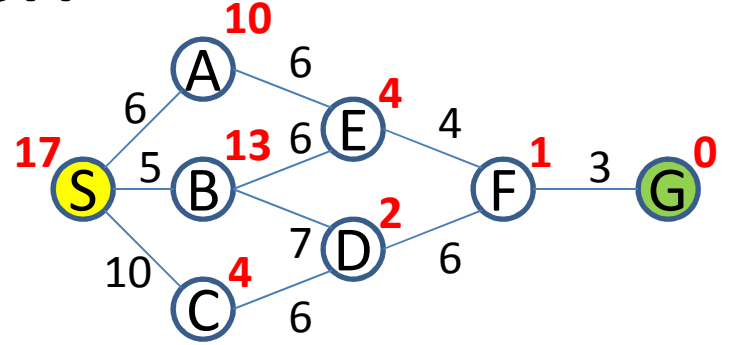
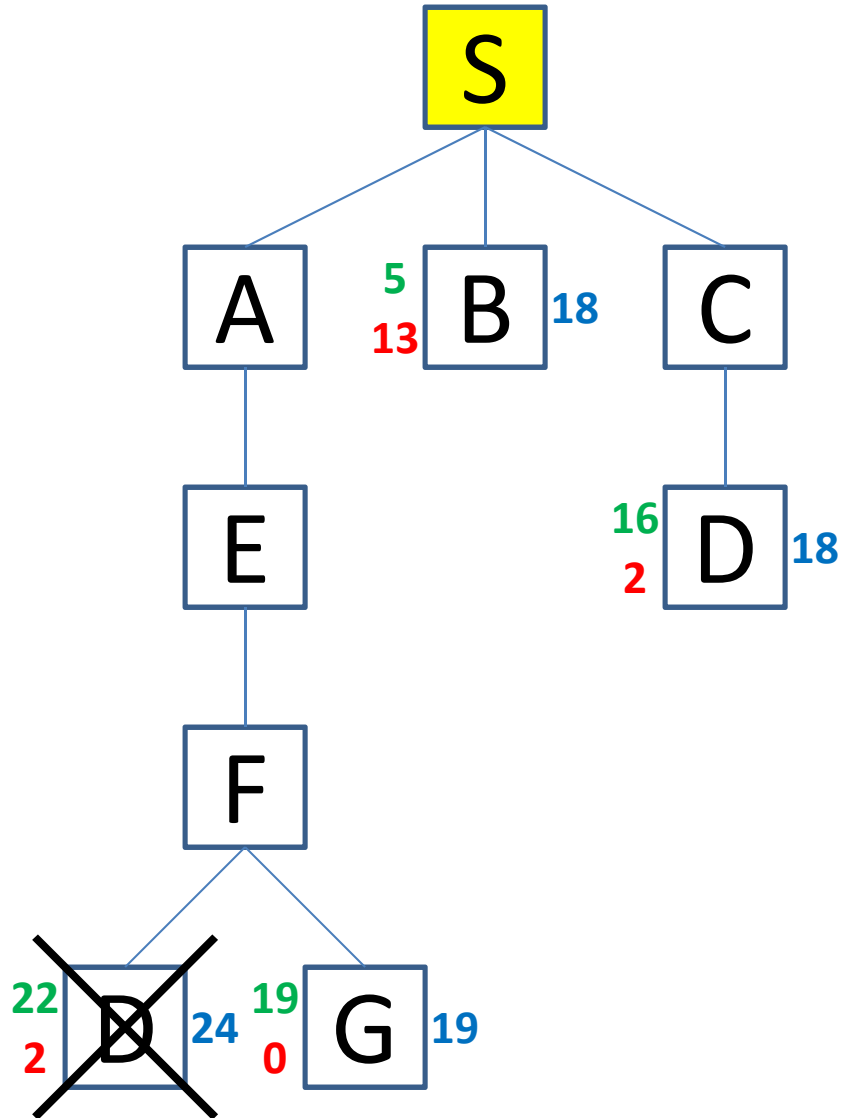

QUEUE:

SCD

SB

SAEFG

SAEFD

A* Search

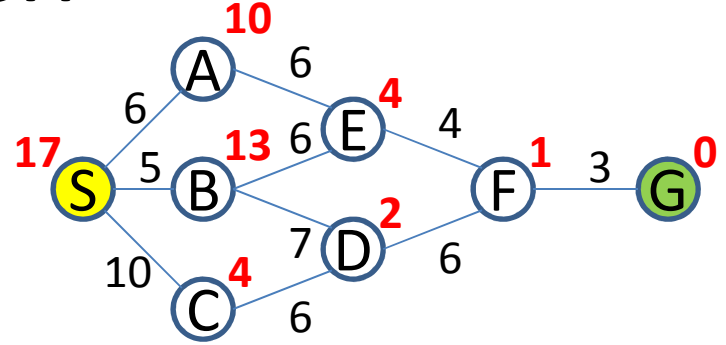
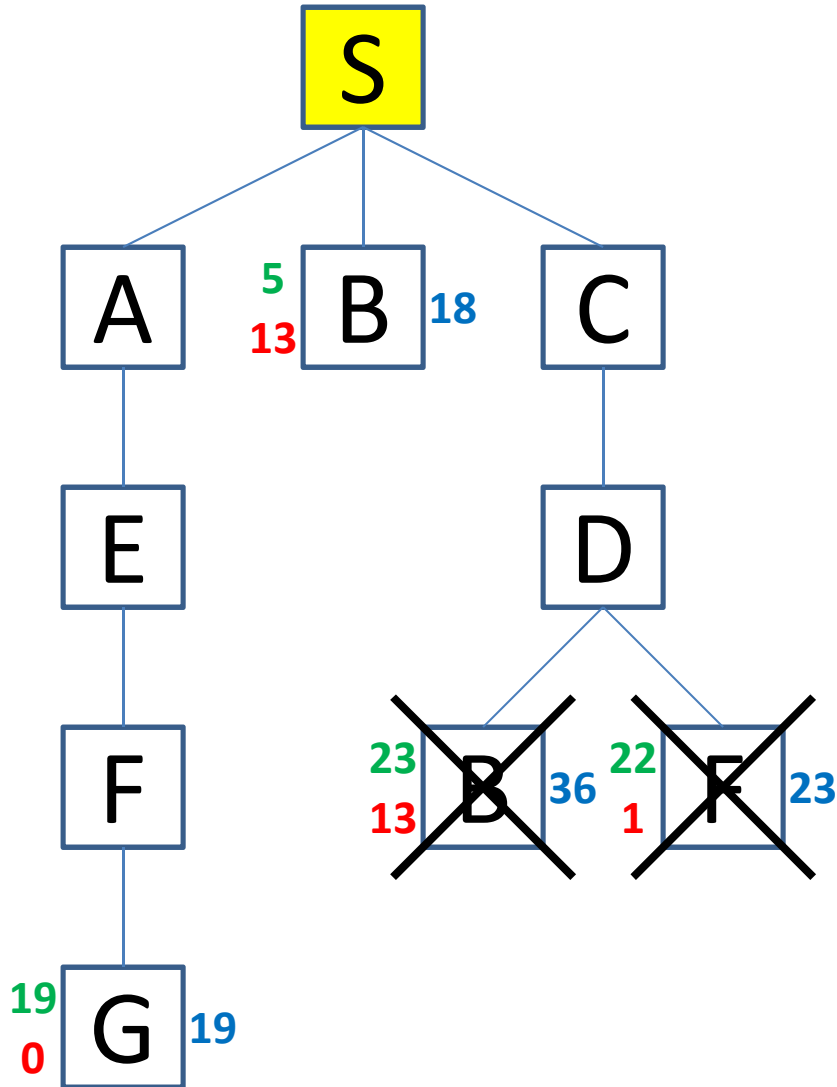

QUEUE:

SB

SAEFG

SCDF

SCDB

A* Search

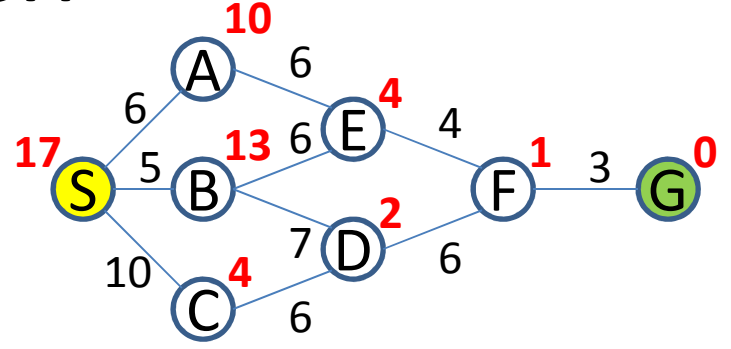
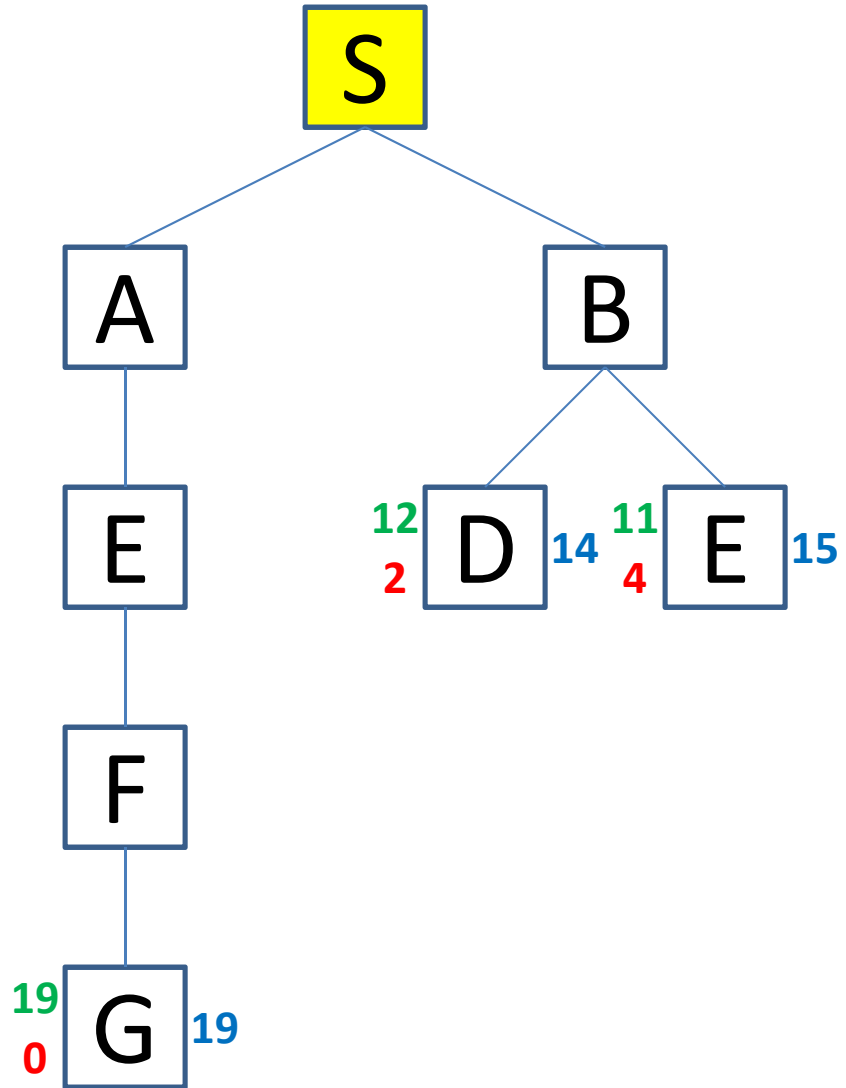

QUEUE:

SBD

SBE

SAEFG

A* Search

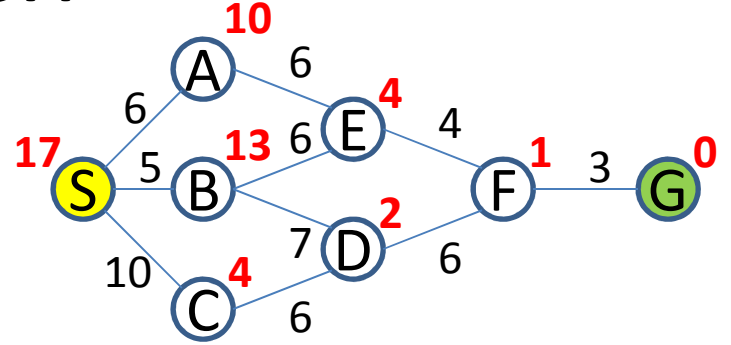
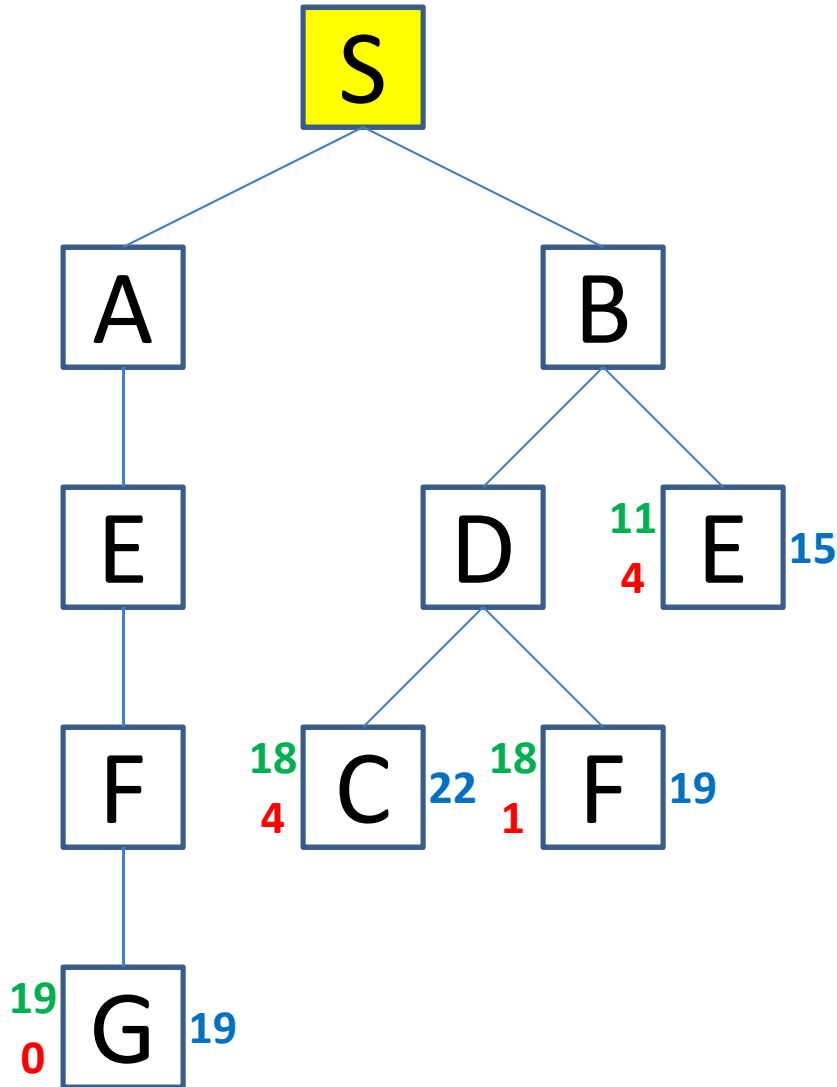

QUEUE:

SBE

SBDF

SAEFG

SBDC

A* Search

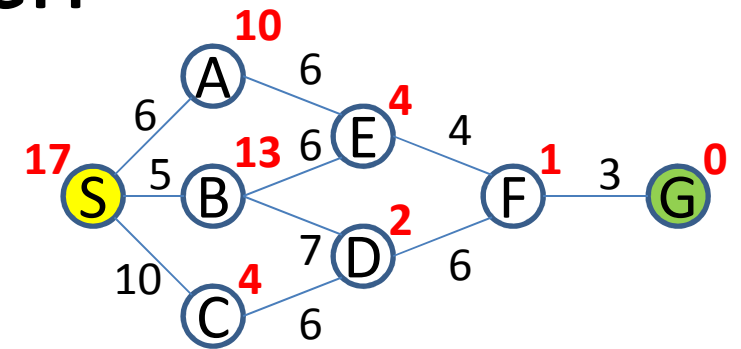
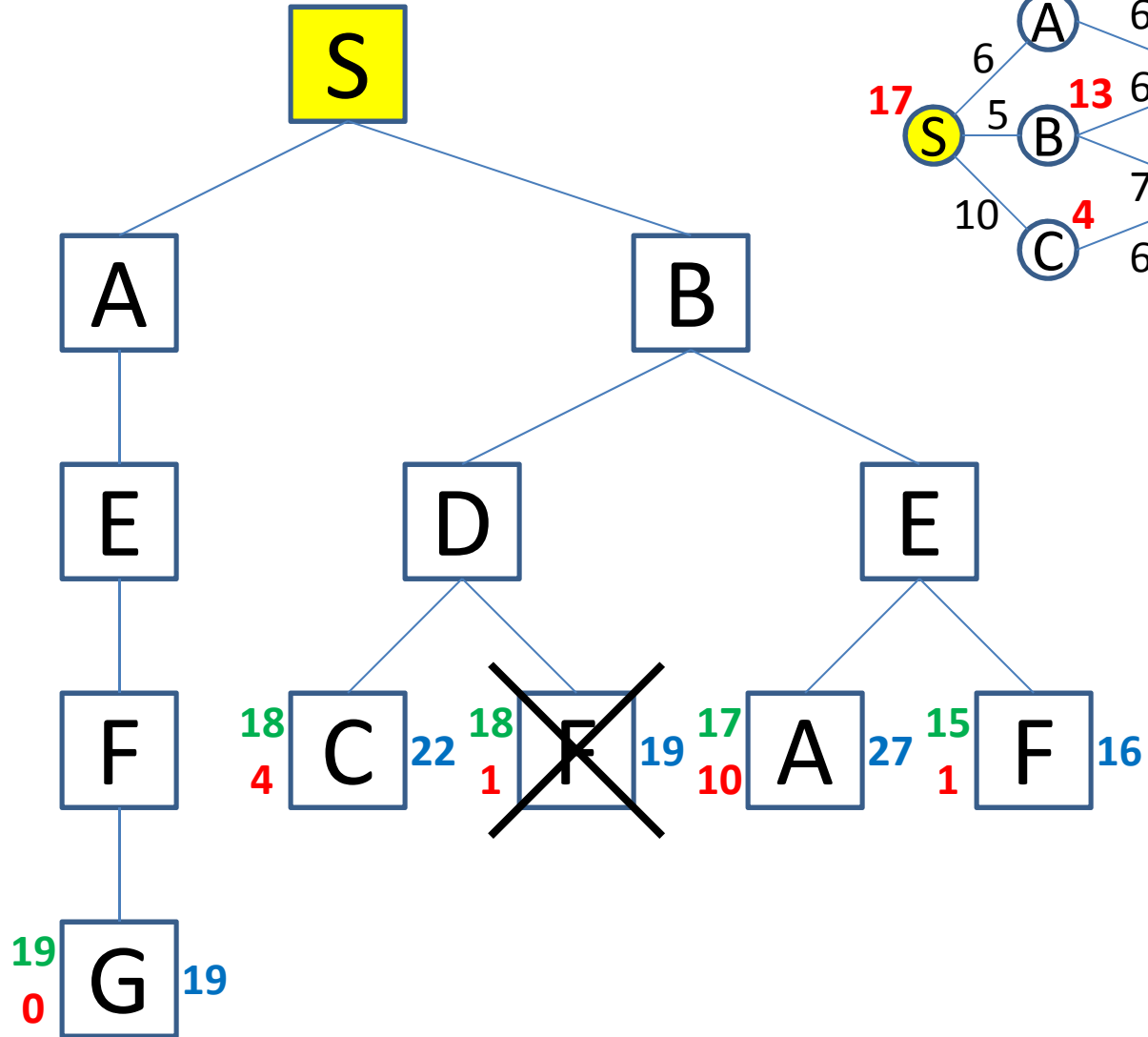

QUEUE:

SBEF

SAEFG

SBDF

SBDC

SBEA

Exercises: Artificial Intelligence

Iterated Deepening A*

IDA* Search

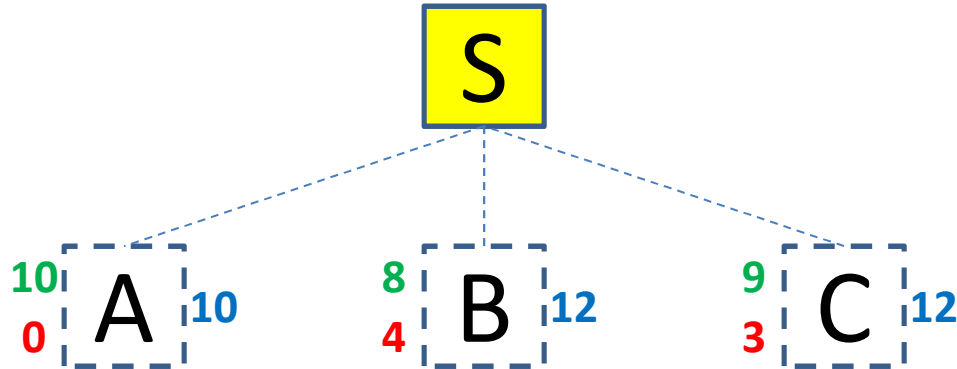

Children are explored depth-first!

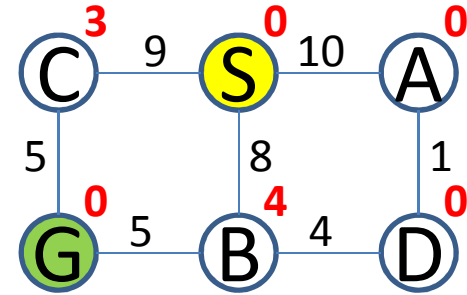

f-bound = 0
f-new = 10

IDA* Search

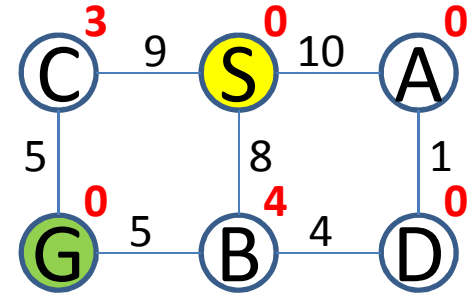
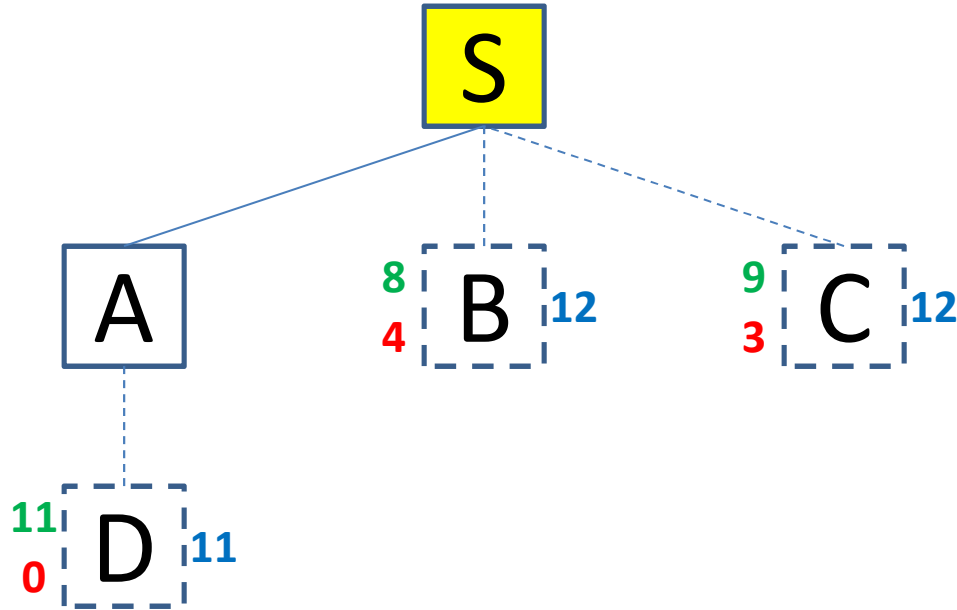

f-bound = 10

f-new = 11

IDA* Search

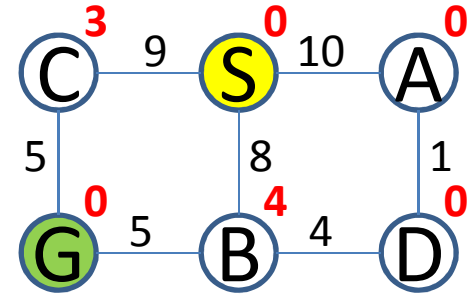
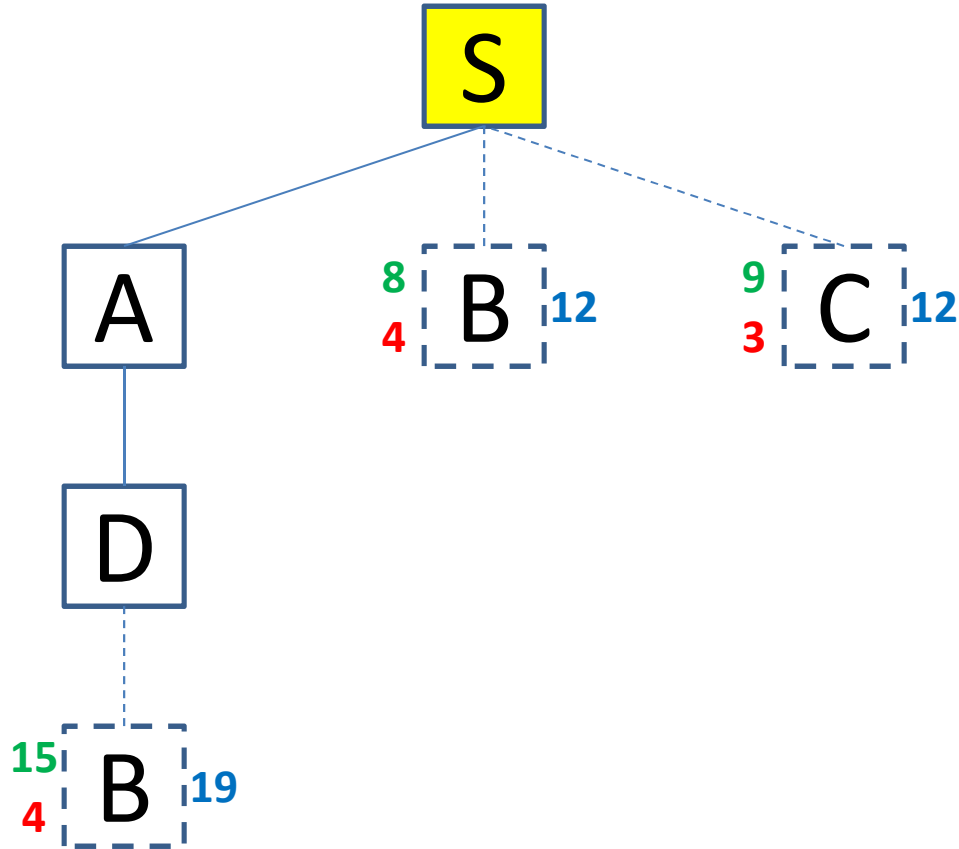

f-bound = 11
f-new = 12

IDA* Search

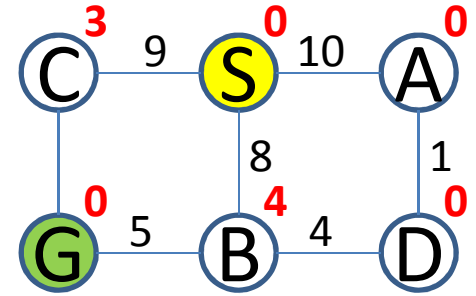
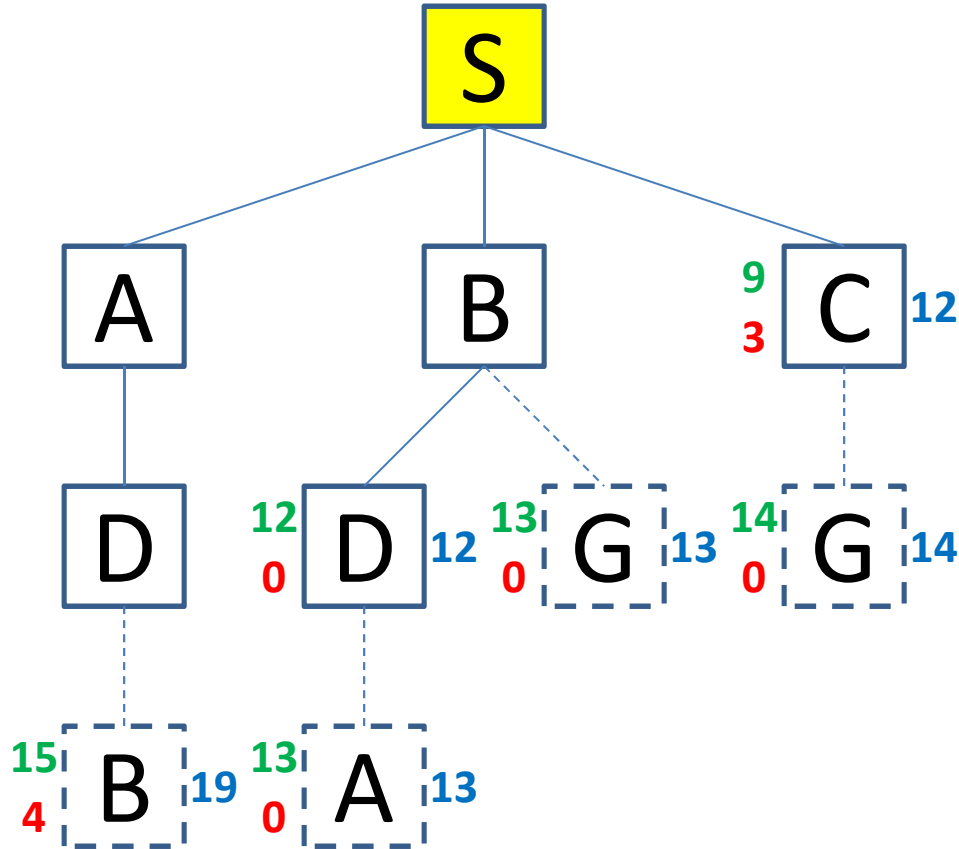

f-bound = 12
f-new = 13

IDA* Search

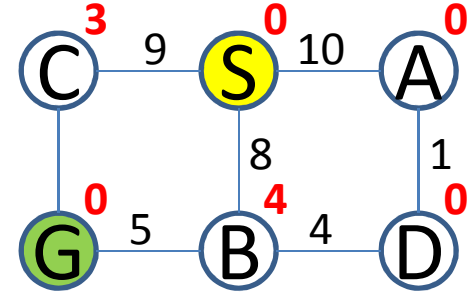
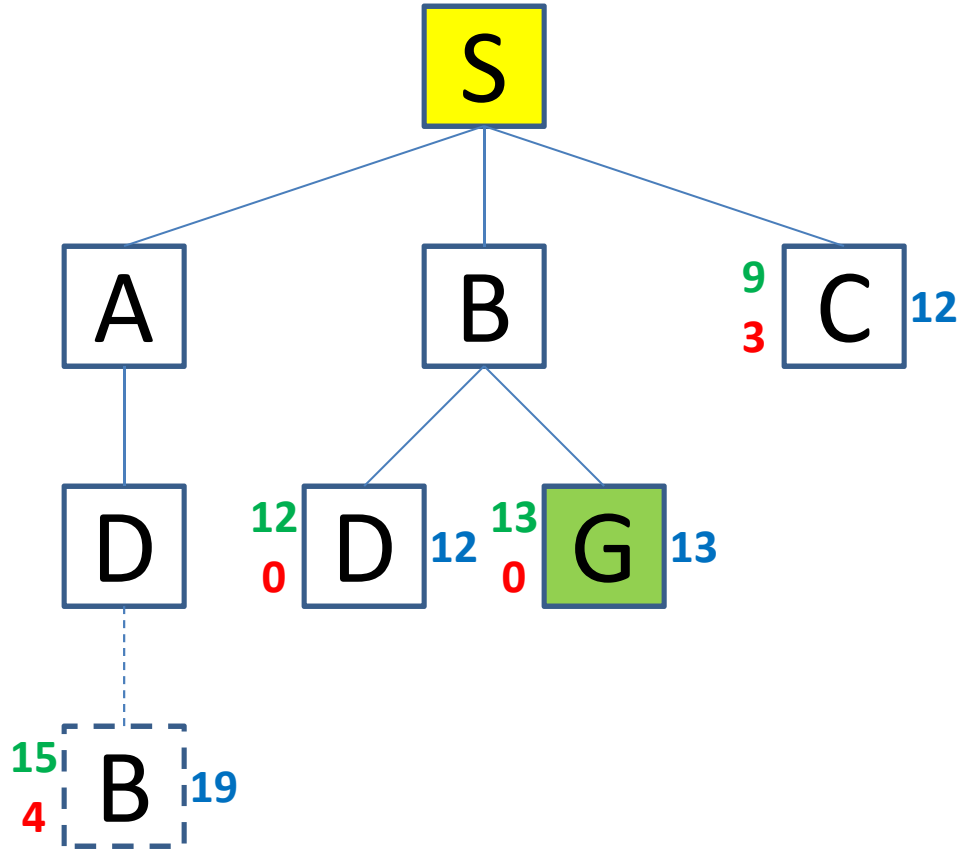

f-bound = 13
f-new = 19

Exercises: Artificial Intelligence

Simplified Memory-bounded A*

Problem

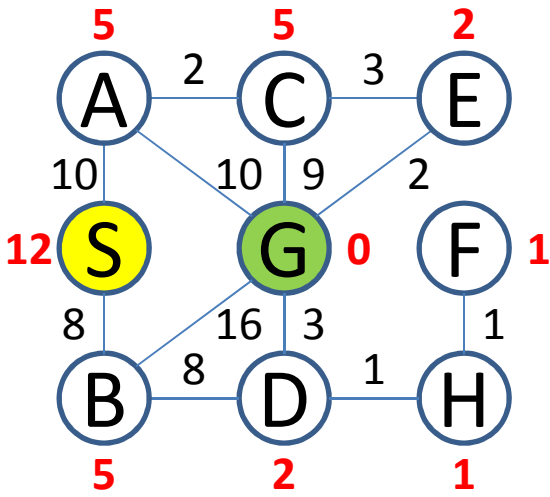

Problem

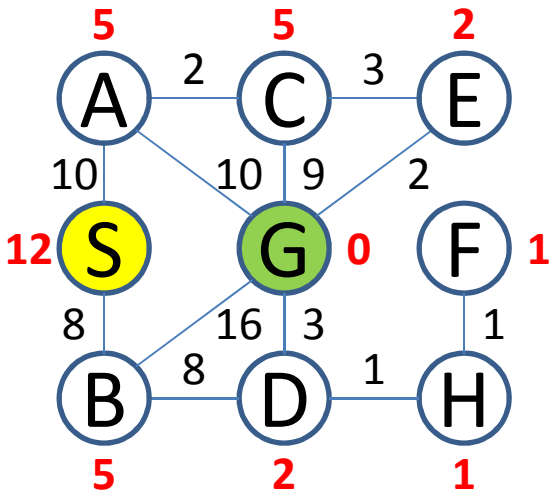
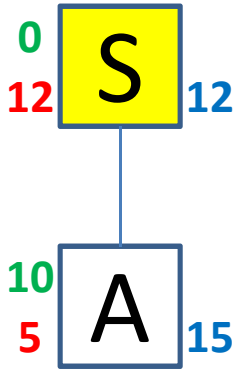

Problem

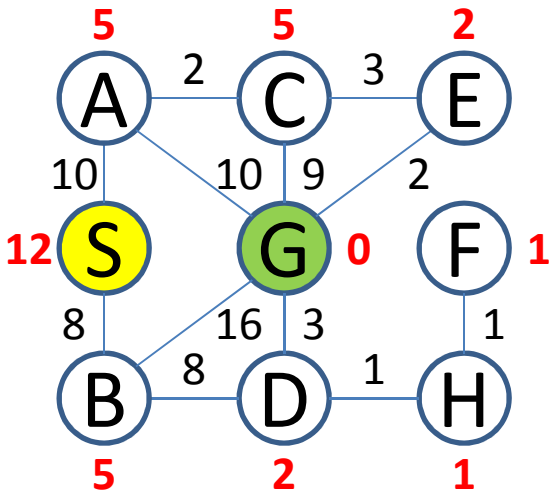
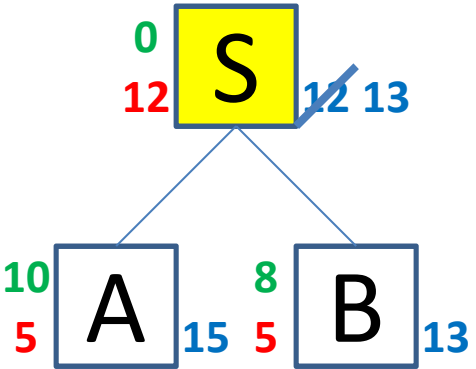

Problem

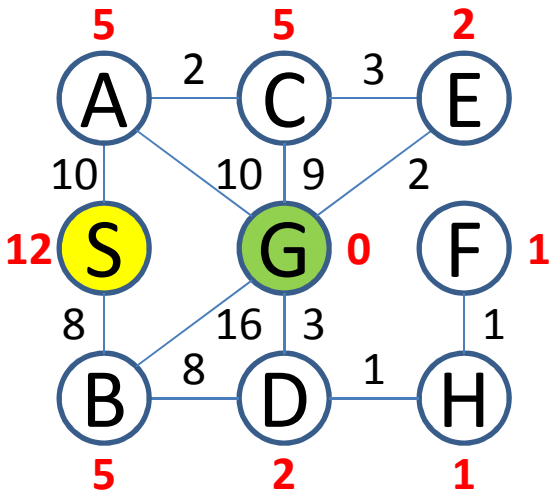
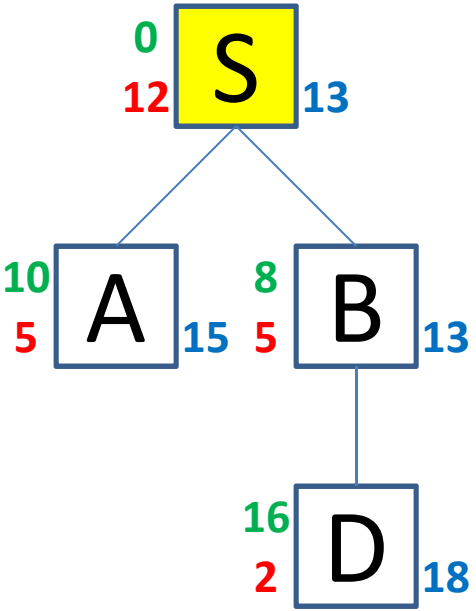

Problem

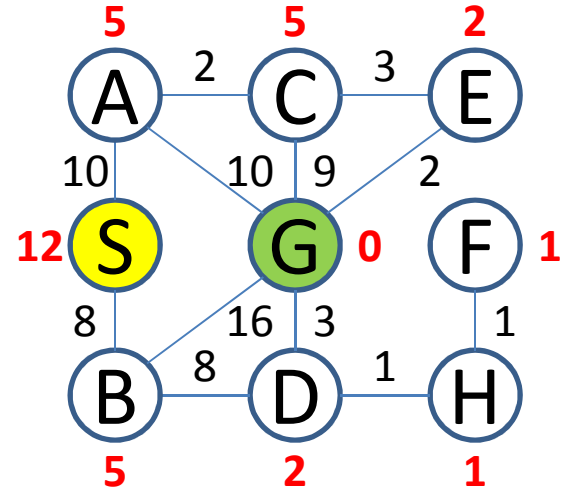
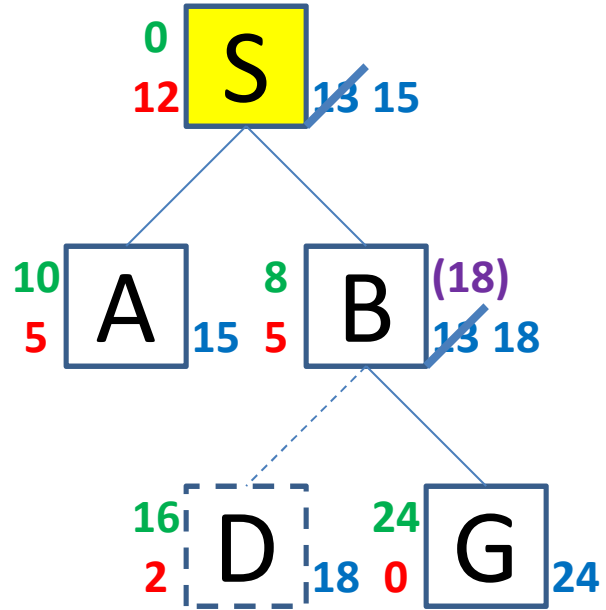

Problem

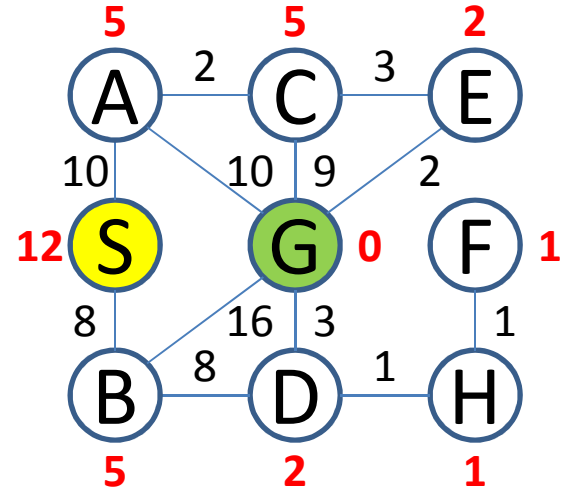
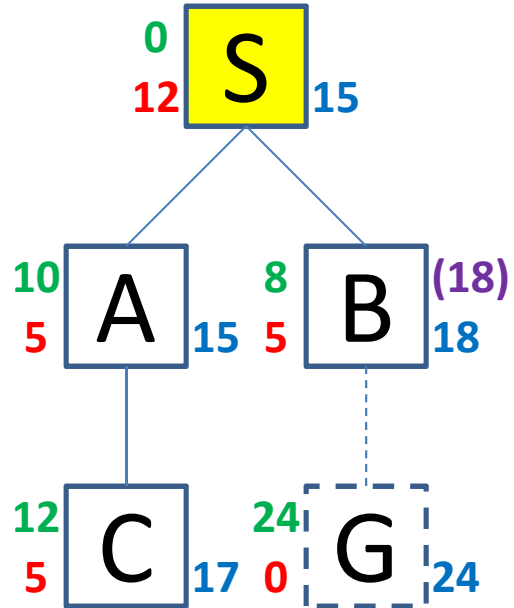

Problem

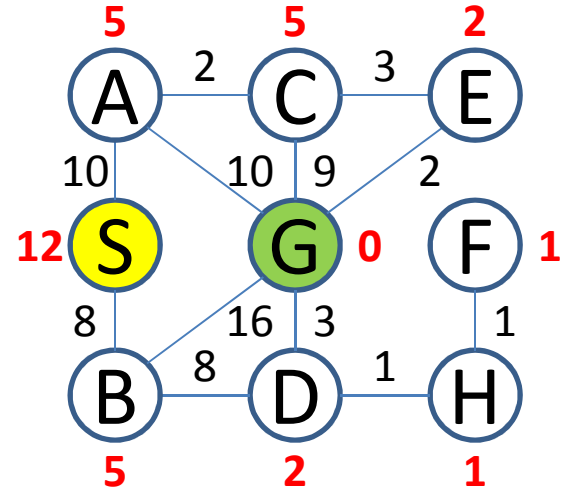
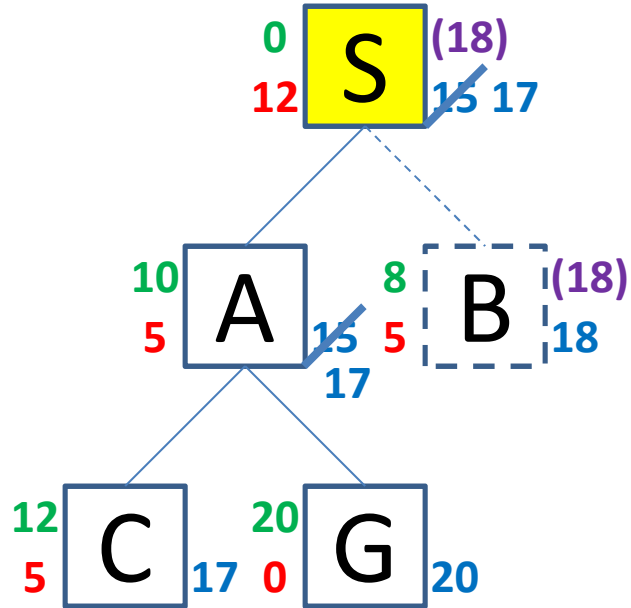

Problem

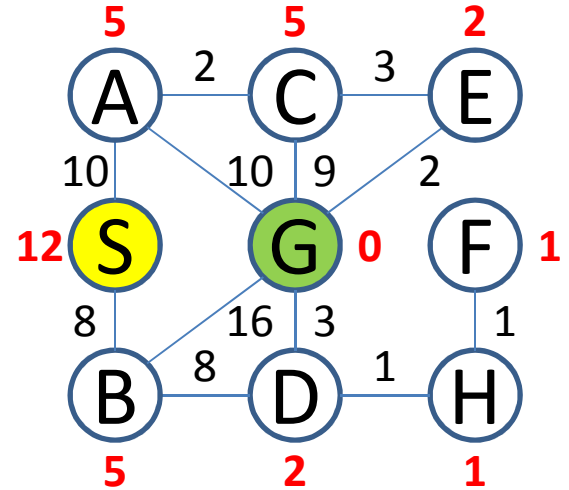
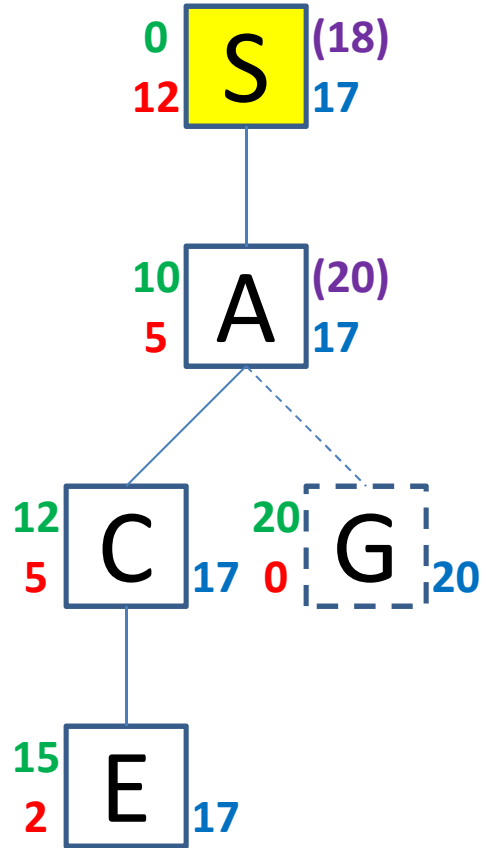

Problem

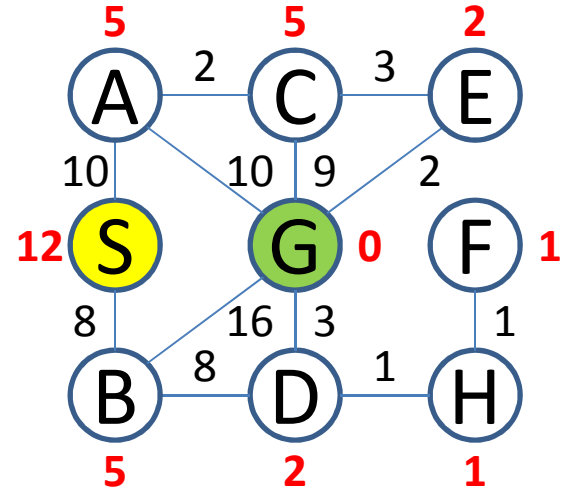
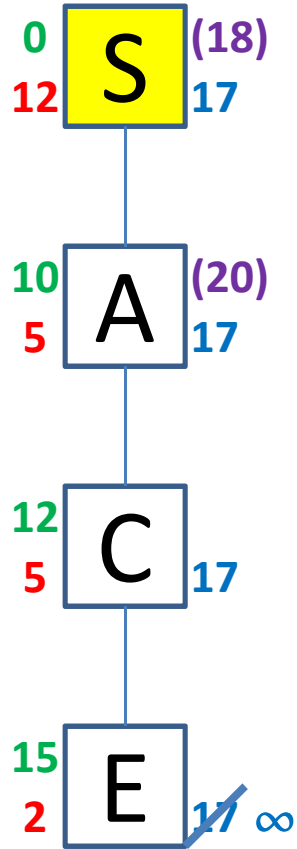

Problem

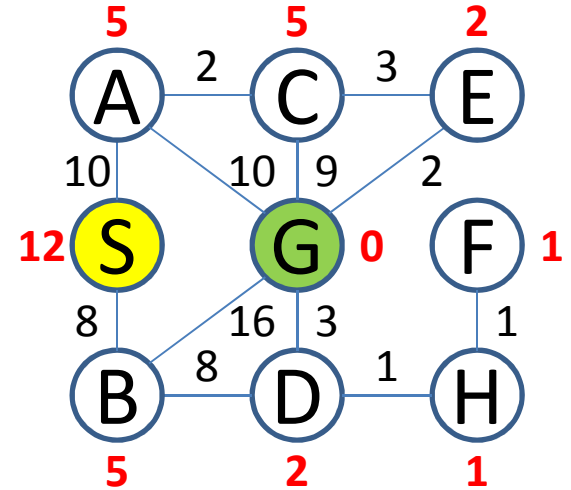
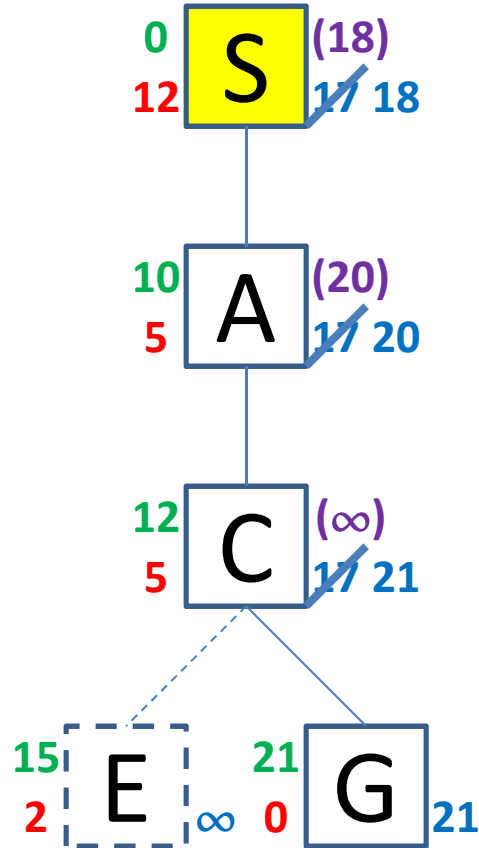

Problem

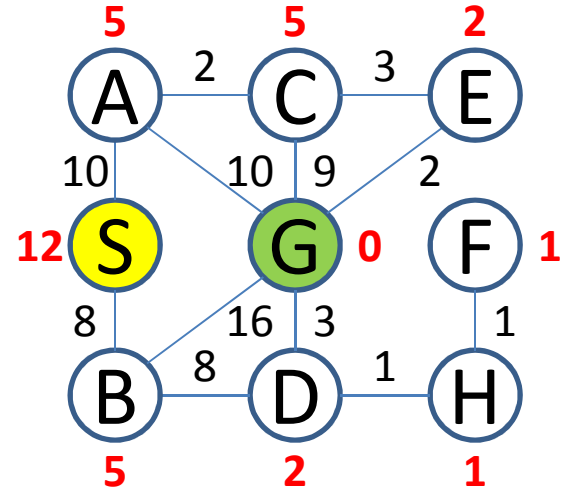
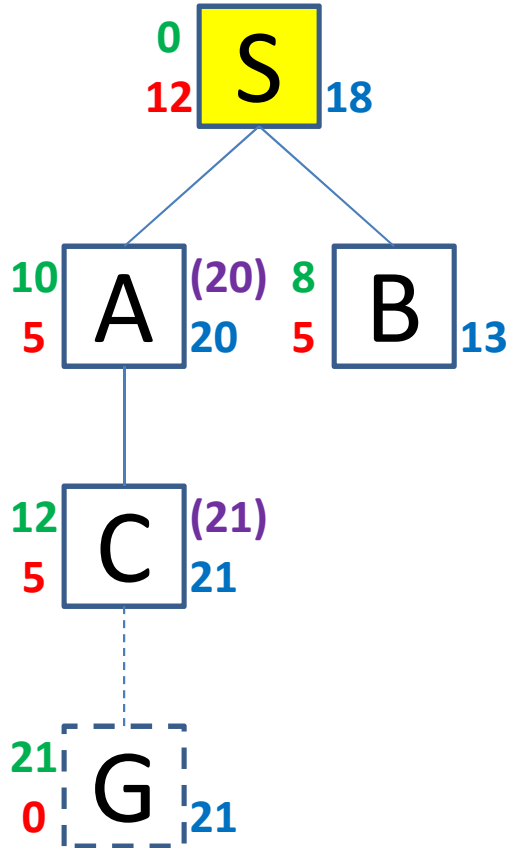

Problem

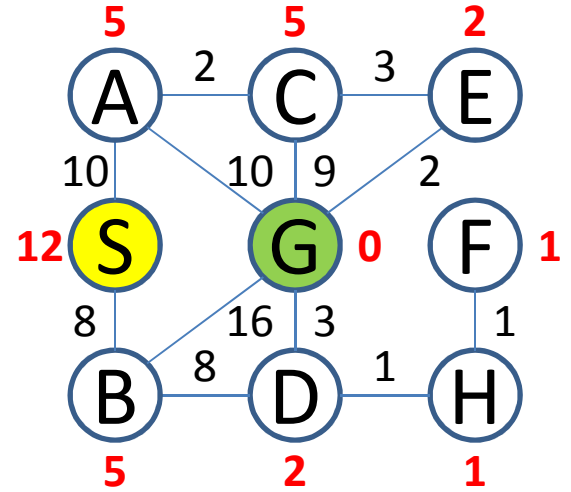
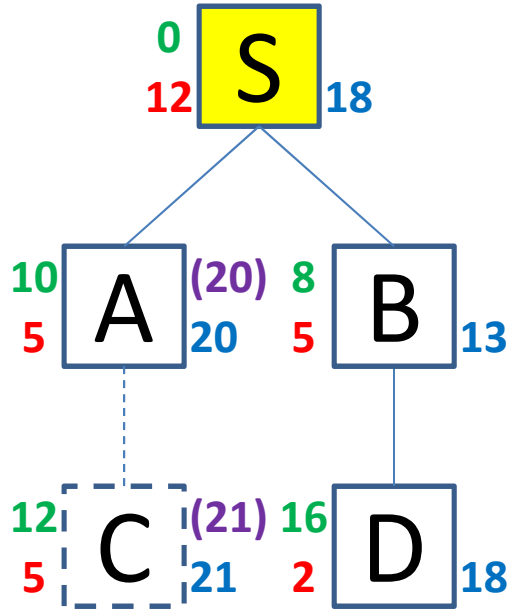

Problem

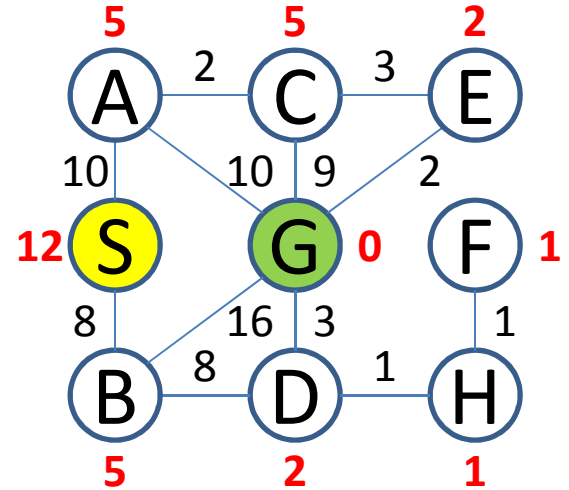
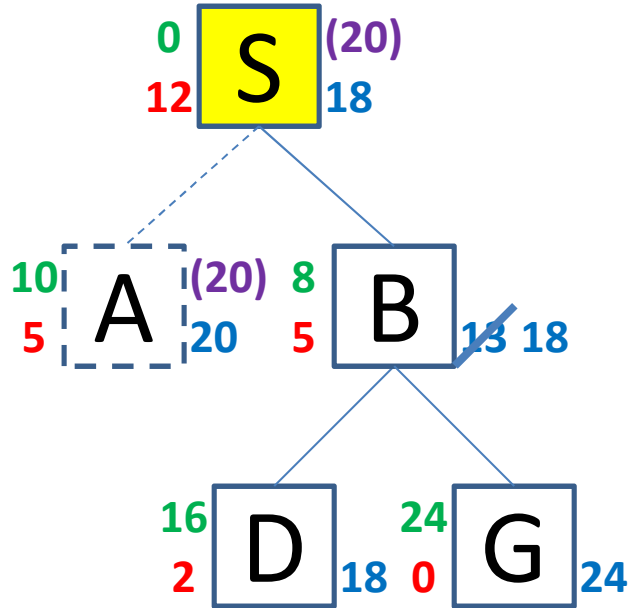

Problem

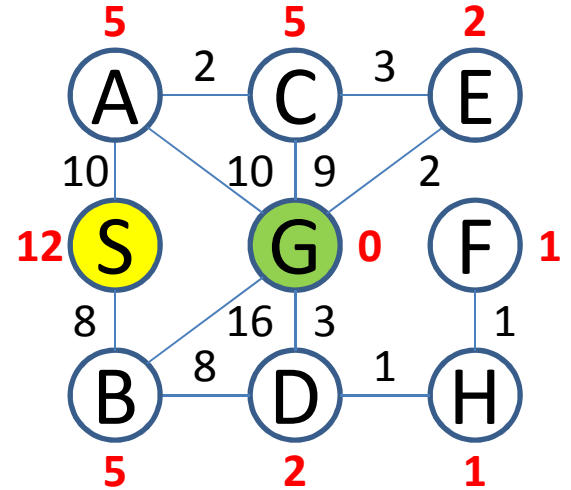
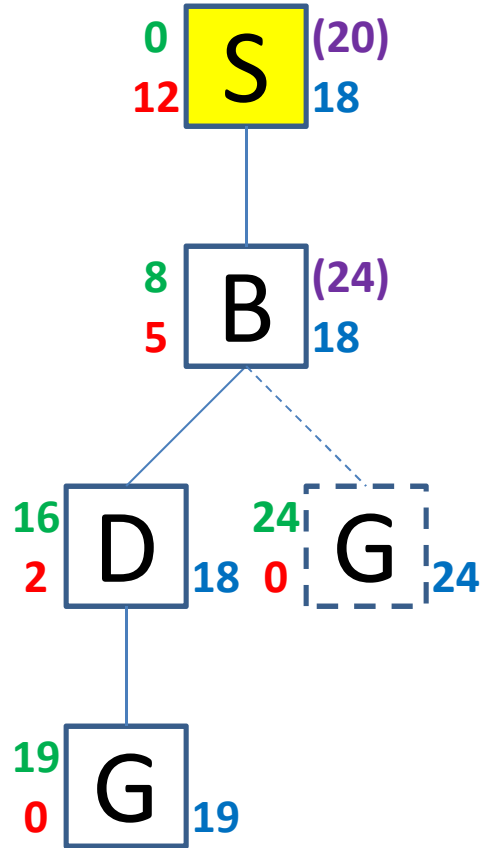

Problem

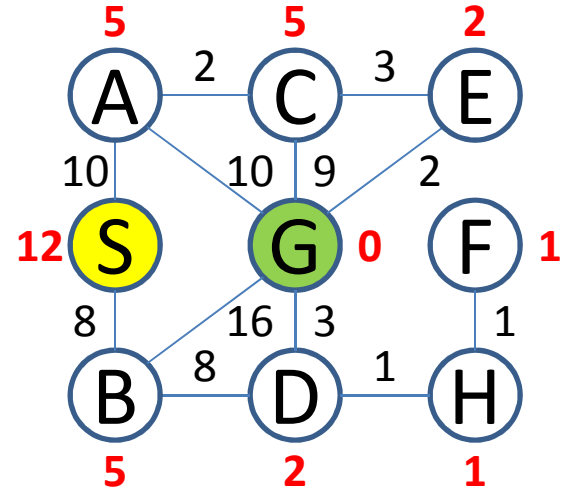
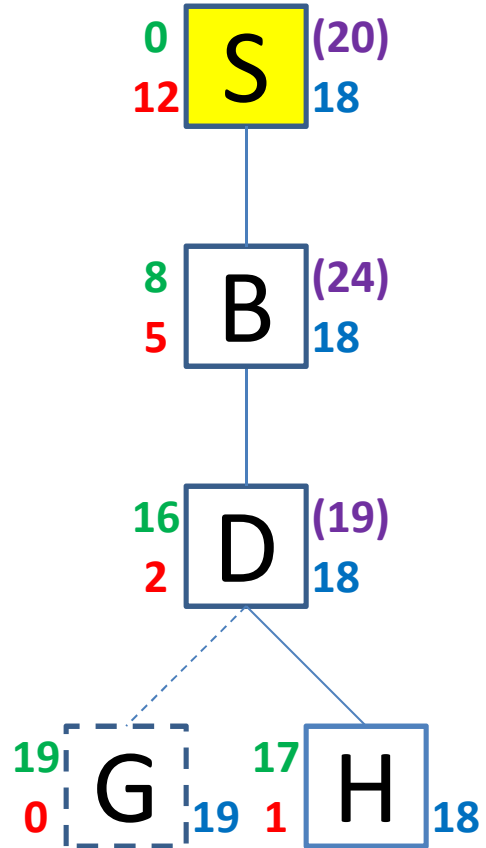

Problem

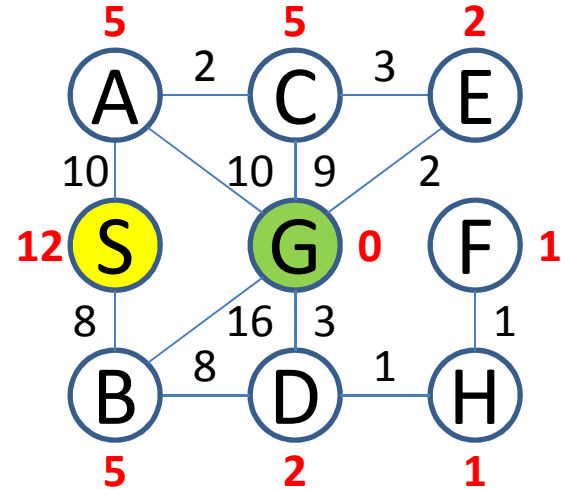
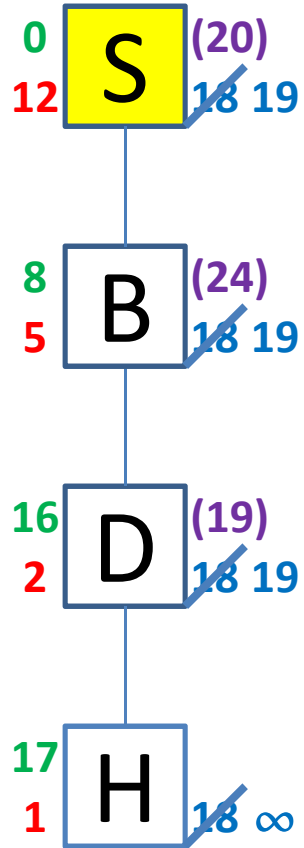

Problem

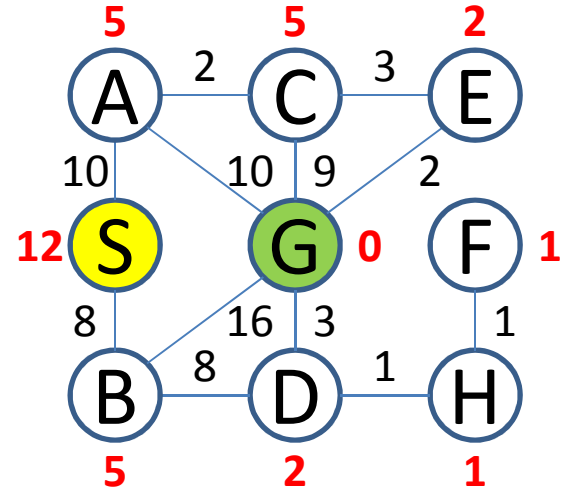
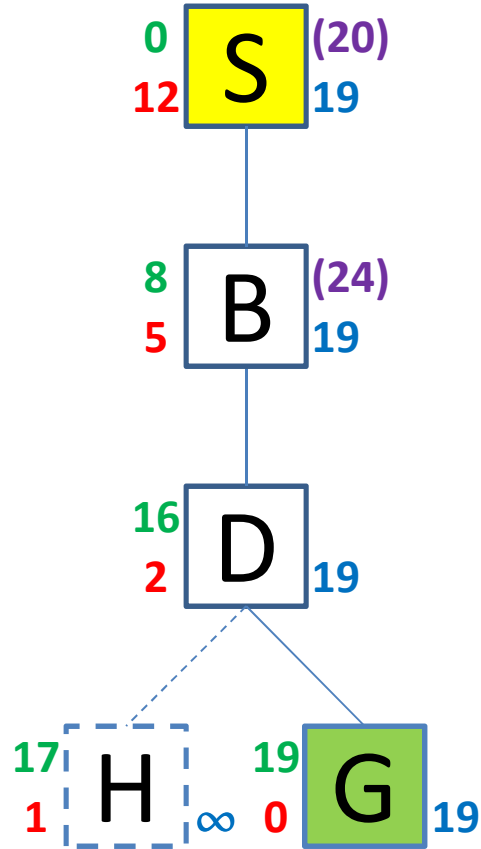

Exercises: Artificial Intelligence

Monotonicity 1

Problem

- Prove that:
 - **IF** a heuristic function h satisfies the *monotonicity restriction*
 - $h(x) \leq \text{cost}(x\dots y) + h(y)$
 - **THEN** f is *monotonously non-decreasing*
 - $f(s\dots x) \leq f(s\dots x\dots y)$

Monotonicity 1

- *Given:*
 - *h* satisfies the *monotonicity restriction*

- *Proof:*

$$\begin{aligned} f(S...A) &= \text{cost}(S...A) + h(A) \\ &\leq \text{cost}(S...A) + \mathbf{\text{cost}(A...B)} + h(B) \\ &\leq \text{cost}(S...A...B) + h(B) \\ &\leq \mathbf{f(S...A...B)} \end{aligned}$$

Exercises: Artificial Intelligence

Monotonicity 2

Problem

- Prove or refute:
 - **IF** f is *monotonously non-decreasing*
 - $f(s...x) \leq f(s...xy)$
 - **THEN** h is an *admissible heuristic*
 - h is an underestimate of the remaining path to the goal with the smallest cost
- Can an extra constraint on h change this?

Monotonicity 2

- *Given:*
 - *f* is monotonously non-decreasing
- *Proof (Counter-example):*

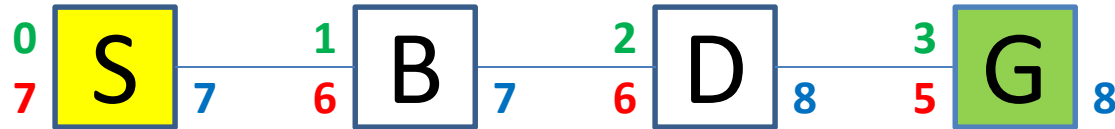

f is monotonously non-decreasing,
yet *h* is not an admissible heuristic.

Monotonicity 2

- *Given:*

- f is monotonously non-decreasing

- Extra constraint: $h(G) = 0$

- *Proof:*

$$\underline{f(S...A) \leq f(S...AB) \leq \dots \leq f(S...AB...G)} \Leftrightarrow$$

$$f(S...A) \leq f(S...G) \Leftrightarrow$$

$$\text{cost}(S...A) + h(A) \leq \text{cost}(S...G) + h(G) \Leftrightarrow$$

$$\underline{\text{cost}(S...A)} + h(A) \leq \underline{\text{cost}(S...A)} + \text{cost}(A...G) + h(G) \Leftrightarrow$$

$$h(A) \leq \text{cost}(A...G) + \underline{h(G)} \Leftrightarrow$$

$$h(A) \leq \text{cost}(A...G)$$