

Exercises: Artificial Intelligence

Planning & Logic: Blocks world

STRIPS

I	
If	
Add	on(A,T)
	on(B,T)
	on(C,T)
	on(D,T)
	clear(A)
	clear(B)
	clear(C)
	clear(D)
Del	

O31 (x/B,z/A)	
If	
If	on(B,T)
	clear(A)
	clear(B)
Add	on(B,A)
Del	on(B,T)
	clear(A)

F	
If	
If	on(A,T)
	on(B,A)
	on(C,B)
	on(D,C)
	clear(D)
Add	
Del	

$B(I,F)$

$B(I,O31)$

$B(I,O31)$

$B(I,O31)$

$B(O31,F)$



Establishes



Threatens

Before constraint:

$B(x,y)$

STRIPS

I	
If	
Add	on(A,T)
	on(B,T)
	on(C,T)
	on(D,T)
	clear(A)
	clear(B)
	clear(C)
	clear(D)
Del	

O31	(x/B,z/A)
-----	-----------

O32	(x/C,z/B)
-----	-----------

If	
Add	on(C,T)
	clear(B)
	clear(C)
Del	on(C,B)
	on(C,T)
	clear(B)

F	
If	
Add	on(A,T)
	on(B,A)
	on(C,B)
	on(D,C)
	clear(D)
Add	
Del	



Establishes



Threatens

$B(O31,O32) \vee B(O32,I)$ ← Loop!

Before constraint:

$B(x,y)$

$B(I,F)$

$B(O31,F)$

$B(O32,F)$

$B(I,O31)$

$B(I,O32)$

STRIPS

I	
If	
Add	on(A,T)
	on(B,T)
	on(C,T)
	on(D,T)
	clear(A)
	clear(B)
	clear(C)
	clear(D)
Del	

F	
If	on(A,T)
	on(B,A)
	on(C,B)
	on(D,C)
	clear(D)
Add	
Del	

O31 (x/B,z/A)

O32 (x/C,z/B)

O33 (x/D,z/C)

If	on(D,T)
	clear(C)
	clear(D)

Add	on(D,C)
-----	---------

Del	on(D,T)
	clear(C)



Establishes



Threatens

Before constraint:

$B(x,y)$

$B(I,O31)$

$B(I,O32)$

$B(I,O33)$

$B(I,F)$

$B(O31,F)$

$B(O32,F)$

$B(O33,F)$

$B(O31,O32)$

$B(O32,O33) \vee B(O33,I)$

Loop!

STRIPS

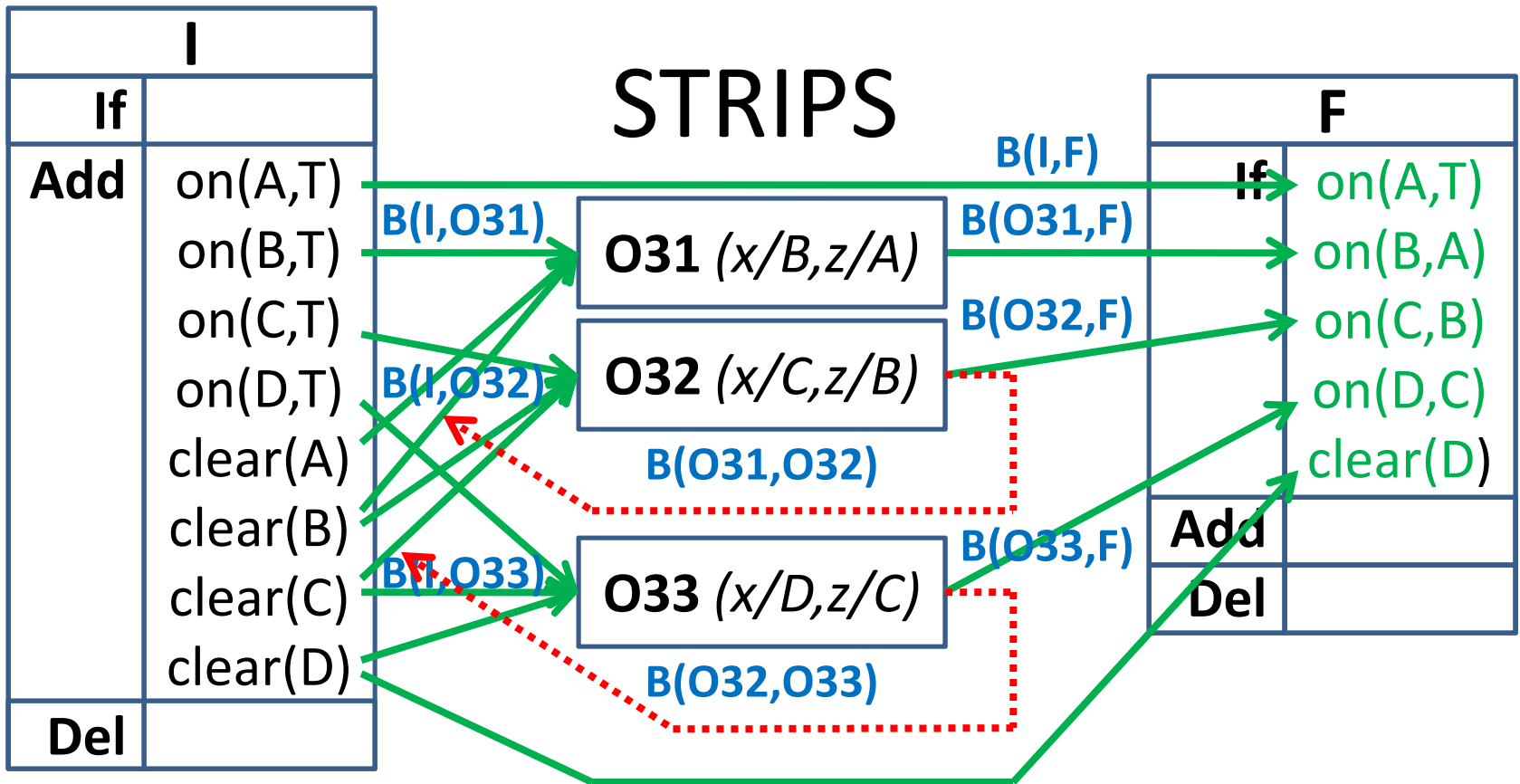

Establishes



Threatens

Before constraint:

$B(x,y)$

STRIPS

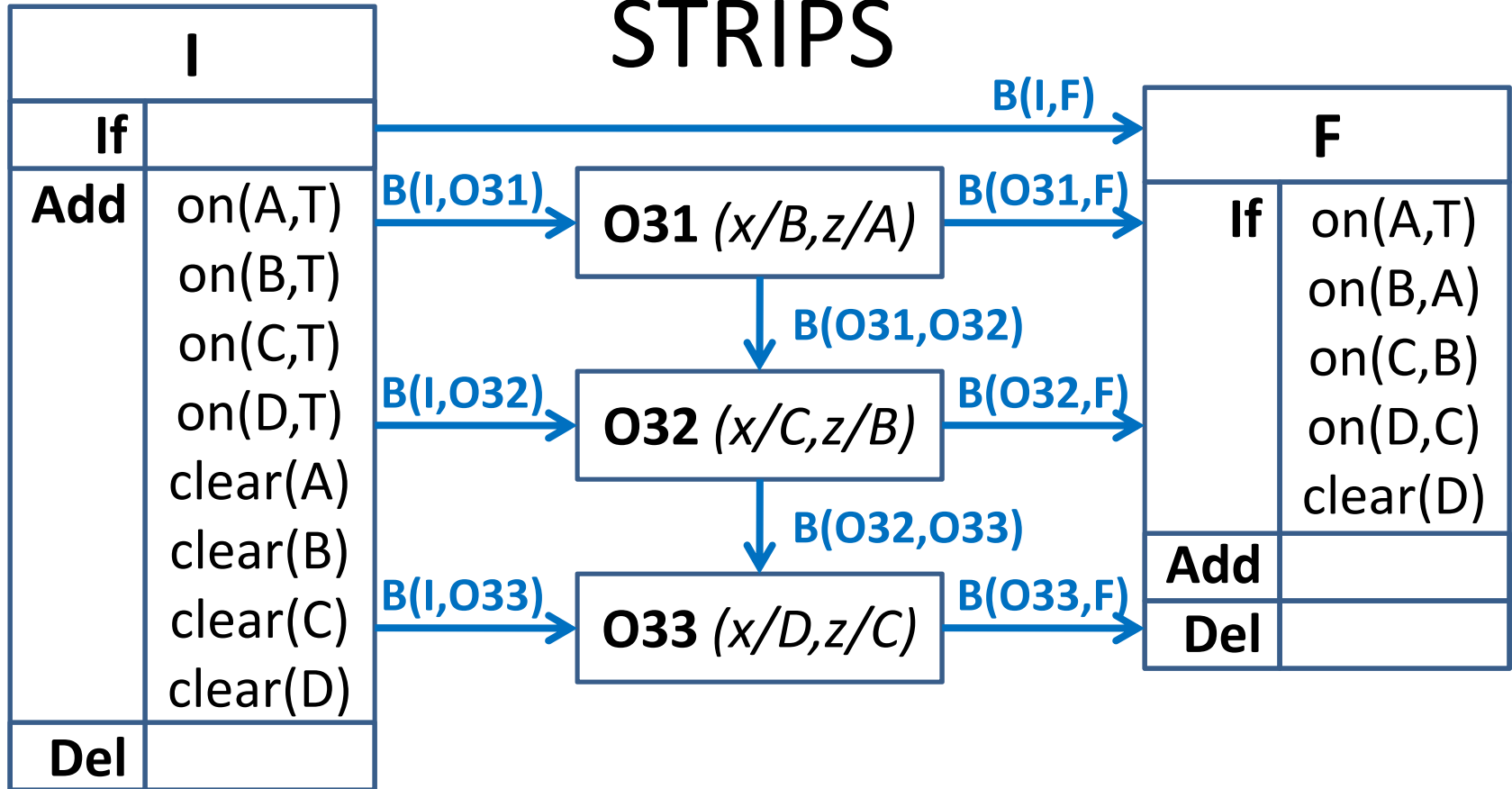

Are the before constraints satisfiable?

YES:

→ **O31** → **O32** → **O33** →

Exercises: Artificial Intelligence

Planning & Logic: Buying milk

STRIPS

I	If	
	Add	at(home)
	Del	

Operator 2		
If	→	at(home)
Add		at(shop)
Del	...	at(home)

Operator 3		
If		at(shop) ←
Add		have(milk)
Del		

F		
If	→	have(milk) at(home)
Add		
Del		

$B(I,O2)$

$B(O2,I) \vee B(F,O2)$

2 x Loop!

$B(I,F)$

$B(O2,O3)$

$B(O3,F)$



Establishes



Threatens

Before constraint:

$B(x,y)$

STRIPS

I	If	
	Add	at(home)
	Del	

Operator 2		
If	at(home)	
Add	at(shop)	
Del	at(home)	

Operator 3		
If	at(shop)	
Add	have(milk)	
Del		

Operator 4		
If	paid at(shop)	
Add	at(home)	
Del	at(shop)	

F		
If	have(milk) at(home)	
Add		
Del		

$B(I,O2)$

$B(O2,O3)$

$B(O2,O4) \vee B(F,O2)$

$B(O3,F)$

$B(O4,F)$

Establishes

Threatens

Before constraint:

$B(x,y)$

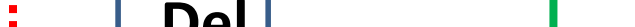
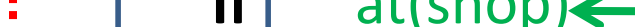

STRIPS

I	If	
	Add	at(home)
	Del	

$B(I, O2)$

Operator 2		
If	→	at(home)
Add		at(shop)
Del		at(home)

$B(O2, O3)$

Operator 3		
If		← at(shop)
Add		have(milk)
Del		

$B(O2, O4)$

$B(O3, F)$

$B(O4, O2) \vee B(O3, O4)$

Operator 4		
If		paid at(shop)
Add		at(home)
Del		at(shop)

$B(O4, F)$

F		
If		have(milk) at(home)
Add		
Del		



Establishes



Threatens

Before constraint:

$B(x, y)$

STRIPS

	If	
I	Add	at(home)
	Del	

Operator 2		
If	→ at(home)	
Add	at(shop)	
Del	at(home)	

Operator 5		
If	→ at(shop)	
	have(money)	
	have(milk)	
Add	paid	
Del	have(money)	

Operator 3		
If	← at(shop)	
Add	have(milk)	
Del		

Operator 4		
If	paid	
	at(shop)	
Add	at(home)	
Del	at(shop)	

F		
If	have(milk)	
	at(home)	
Add		
Del		



Establishes



Threatens

Before constraint:

$B(x,y)$

$B(I,O2)$

$B(O4,O2) \vee B(O5,O4)$

$B(O2,O5)$

$B(O5,O4)$

$B(O2,O3)$

$B(O3,O4)$

$B(O5,O4)$

$B(O2,O4)$

$B(O3,F)$

$B(O4,F)$

STRIPS

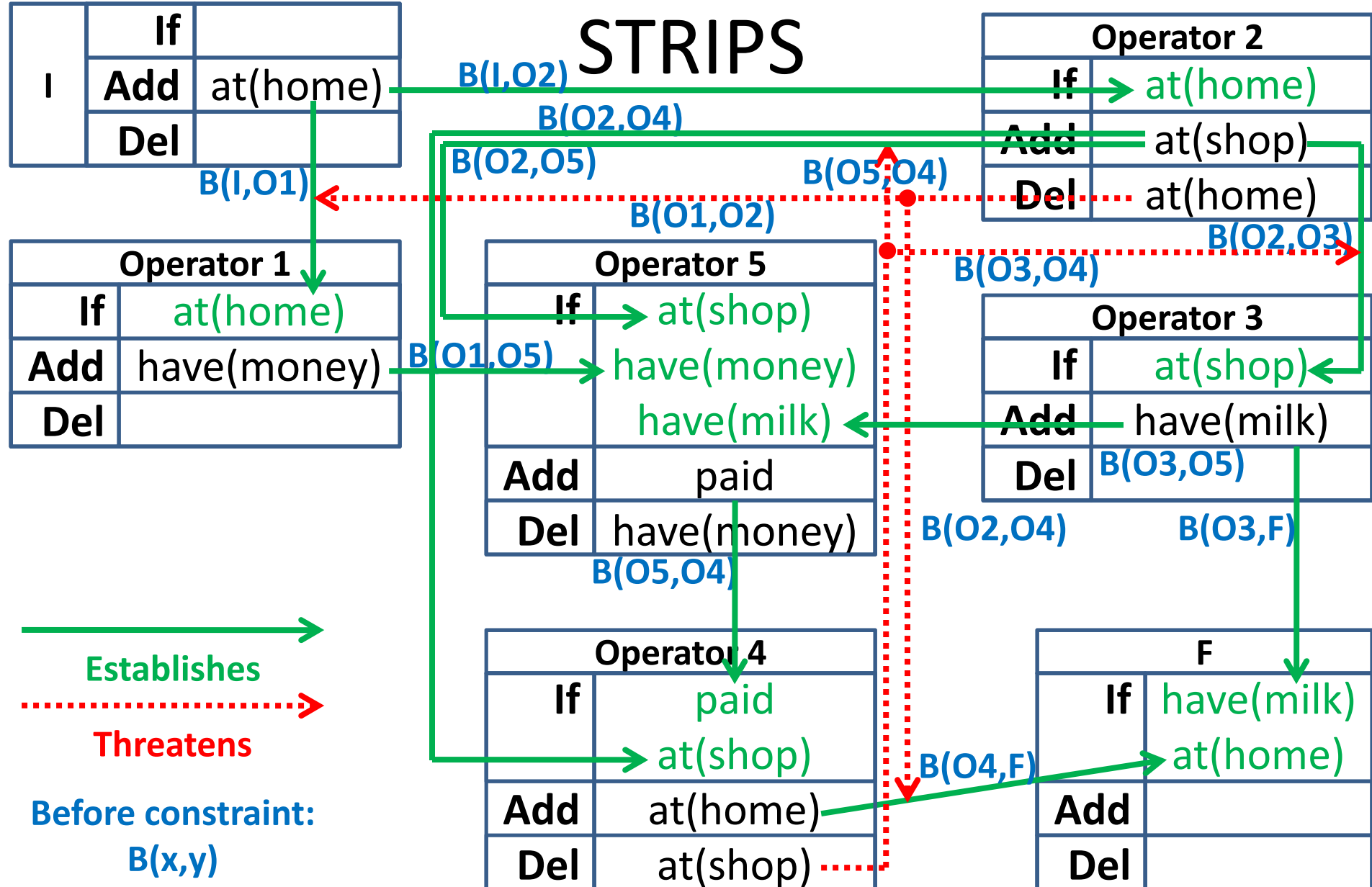

STRIPS

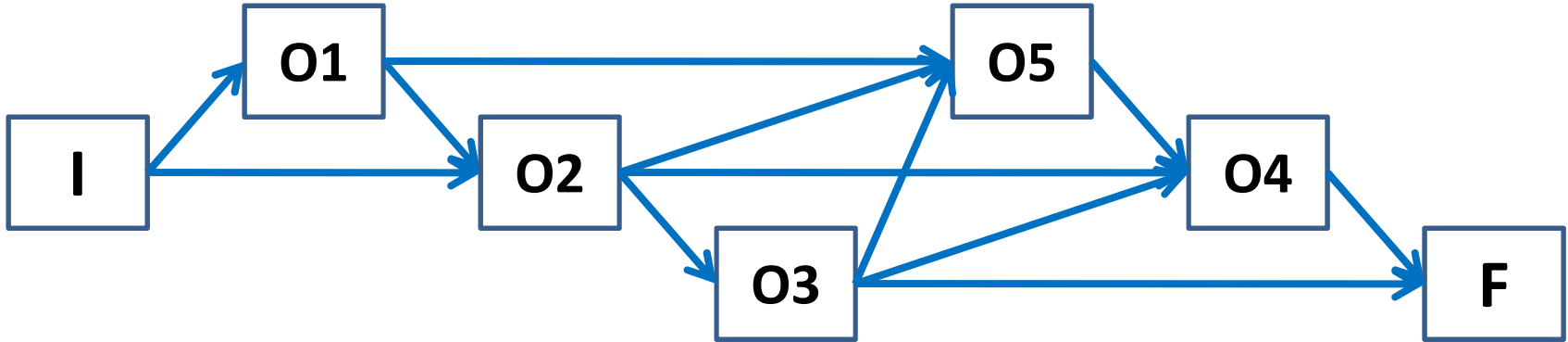

Are the before constraints satisfiable?

YES:

→ O1 → O2 → O3 → O5 → O4 →

Exercises: Artificial Intelligence

Planning & Logic: English to Logic

Problem & Solution

- *Not all students take both history and biology*

$$\neg \forall x [\text{student}(x) \Rightarrow \text{takes}(x, \text{hist}) \wedge \text{takes}(x, \text{bio})]$$

$$\Leftrightarrow [A \Rightarrow B \Leftrightarrow \neg A \vee B]$$

$$\neg \forall x [\neg [\text{student}(x)] \vee [\text{takes}(x, \text{hist}) \wedge \text{takes}(x, \text{bio})]]$$

$$\Leftrightarrow [\neg \forall x (F) \Leftrightarrow \exists x (\neg F)]$$

$$\exists x \neg [\neg [\text{student}(x)] \vee [\text{takes}(x, \text{hist}) \wedge \text{takes}(x, \text{bio})]]$$

$$\Leftrightarrow [\neg(A \vee B) \Leftrightarrow \neg A \wedge \neg B], [\neg(A \wedge B) \Leftrightarrow \neg A \vee \neg B]$$

$$\exists x [\text{student}(x) \wedge [\neg \text{takes}(x, \text{hist}) \vee \neg \text{takes}(x, \text{bio})]]$$

Problem & Solution

- *No person likes a smart vegetarian*

$$\forall x \forall y [\text{person}(x) \wedge \text{vegetarian}(y) \wedge \text{smart}(y) \Rightarrow \neg \text{likes}(x,y)]$$

$$\Leftrightarrow [A \Rightarrow B \Leftrightarrow \neg A \vee B]$$

$$\forall x \forall y [\neg[\text{person}(x) \wedge \text{vegetarian}(y) \wedge \text{smart}(y)] \vee \neg \text{likes}(x,y)]$$

$$\Leftrightarrow [\neg A \vee \neg B \Leftrightarrow \neg(A \wedge B)]$$

$$\forall x \forall y \neg[\text{person}(x) \wedge \text{vegetarian}(y) \wedge \text{smart}(y) \wedge \text{likes}(x,y)]$$

$$\Leftrightarrow [\forall x \neg(F) \Leftrightarrow \neg \exists x (F)]$$

$$\neg \exists x \exists y [\text{person}(x) \wedge \text{vegetarian}(y) \wedge \text{smart}(y) \wedge \text{likes}(x,y)]$$

Problem & Solution

- *There is a woman who likes all men who are not vegetarians.*

$$\exists x[\text{woman}(x) \wedge [\forall y [\text{man}(y) \wedge \neg \text{vegetarian}(y) \Rightarrow \text{likes}(x,y)]]]$$

Problem & Solution

- *The best score in history was better than the best score in biology.*

$$\forall x \forall y [\text{bestscore}(\text{hist},x) \wedge \text{bestscore}(\text{bio},y) \Rightarrow \text{better}(x,y)]$$

Problem & Solution

- *Every person who dislikes all vegetarians is smart.*

$$\forall x [\text{person}(x) \wedge [\forall y [\text{vegetarian}(y) \Rightarrow \neg \text{likes}(x,y)]] \Rightarrow \text{smart}(x)]$$

Problem & Solution

- *There is a barber who shaves all men in town who do not shave themselves.*

$$\exists x [\text{barber}(x) \wedge [\forall y [\text{townsman}(y) \wedge \neg \text{shaves}(y,y) \Rightarrow \text{shaves}(x,y)]]]$$

$$\Leftrightarrow$$

$$\exists x [\text{barber}(x) \wedge [\forall y [\neg [\text{townsman}(y) \wedge \neg \text{shaves}(y,y)] \vee \text{shaves}(x,y)]]]$$

$$\Leftrightarrow$$

$$\exists x [\text{barber}(x) \wedge [\forall y \neg [\text{townsman}(y) \wedge \neg \text{shaves}(y,y) \wedge \neg \text{shaves}(x,y)]]]$$

$$\Leftrightarrow$$

$$\exists x [\text{barber}(x) \wedge [\neg \exists y [\text{townsman}(y) \wedge \neg \text{shaves}(y,y) \wedge \neg \text{shaves}(x,y)]]]$$

Problem & Solution

- *No person likes a professor unless the professor is smart.*

$$\forall x \forall y [\text{person}(x) \wedge \text{professor}(y) \Rightarrow [\text{likes}(x,y) \Rightarrow \text{smart}(y)]] \Leftrightarrow$$

$$\forall x \forall y [\text{person}(x) \wedge \text{professor}(y) \Rightarrow [\neg \text{likes}(x,y) \vee \text{smart}(y)]] \Leftrightarrow$$

$$\forall x \forall y [\neg [\text{person}(x) \wedge \text{professor}(y)] \vee [\neg \text{likes}(x,y) \vee \text{smart}(y)]] \Leftrightarrow$$

$$\forall x \forall y [\neg [\text{person}(x) \wedge \text{professor}(y)] \vee \neg [\text{likes}(x,y) \wedge \neg \text{smart}(y)]] \Leftrightarrow$$

$$\forall x \forall y \neg [\text{person}(x) \wedge \text{professor}(y) \wedge \text{likes}(x,y) \wedge \neg \text{smart}(y)] \Leftrightarrow$$

$$\neg \exists x \exists y [\text{person}(x) \wedge \text{professor}(y) \wedge \text{likes}(x,y) \wedge \neg \text{smart}(y)]$$

Problem & Solution

- *Only one person failed both history and biology.*

$$\exists!x \text{ student}(x) \wedge \text{failed}(x, \text{hist}) \wedge \text{failed}(x, \text{bio})$$

Note that: $\exists!x p(x) \Leftrightarrow \exists x p(x) \wedge [\forall y [p(y) \Rightarrow x=y]]$

Problem & Solution

- *Politicians can fool some of the people all the time, and they can fool all of the people some of the time, but they can't fool all the people all of the time.*

$\forall x [\text{politician}(x) \Rightarrow [\exists y \text{ people}(y) \wedge [\forall t \text{ time}(t) \Rightarrow \text{fool}(x,y,t)]]]$

$\forall x [\text{politician}(x) \Rightarrow [\exists t \text{ time}(t) \wedge [\forall y \text{ people}(y) \Rightarrow \text{fool}(x,y,t)]]]$

$\forall x [\text{politician}(x) \Rightarrow \neg[\forall y \forall t [\text{people}(y) \wedge \text{time}(t)] \Rightarrow \text{fool}(x,y,t)]]]$

Exercises: Artificial Intelligence

Planning & Logic: And-Or-If

Problem & Solution

- *One more outburst like that and you are in contempt of court.*

outburst \Rightarrow court

NOT: outburst \wedge court

Problem & Solution

- *Either the Red Sox win or I'm out ten dollars.*

redSoxWin \Leftrightarrow \neg outTenDollars

NOT: redSoxWin \vee outTenDollars

Problem & Solution

- *Maybe I'll come to the party and maybe I won't.*

maybeComeToParty \vee \neg maybeComeToParty

NOT: maybeComeToParty \wedge \neg maybeComeToParty

Exercises: Artificial Intelligence

Planning & Logic: Weird Logic

Problem & Solution

- *I don't jump off the Empire State Building implies if I jump off the Empire State Building, then I float safely to the ground.*
 - *Translating the meaning of the sentence is not possible*

$$\begin{aligned} & \neg \text{jumpESB} \Rightarrow [\text{jumpESB} \Rightarrow \text{floatTTGround}] \Leftrightarrow \\ & \neg \text{jumpESB} \Rightarrow [\neg \text{jumpESB} \vee \text{floatTTGround}] \Leftrightarrow \\ & \text{jumpESB} \vee \neg \text{jumpESB} \vee \text{floatTTGround} \end{aligned}$$

Problem & Solution

- *It is not the case that if you attempt this exercise you will get an F. Therefore, you will attempt this exercise.*
 - *Translating the meaning of the sentence is not possible*

$$\neg[\text{attempt} \Rightarrow \text{getF}] \Rightarrow \text{attempt} \Leftrightarrow$$

$$\neg[\neg\text{attempt} \vee \text{getF}] \Rightarrow \text{attempt} \Leftrightarrow$$

$$\neg\text{attempt} \vee \text{getF} \vee \text{attempt}$$