

Exercises: Artificial Intelligence

Constraint Processing II & Waltz: The
4 Teachers problem

Problem Optimization

- Problem optimization:

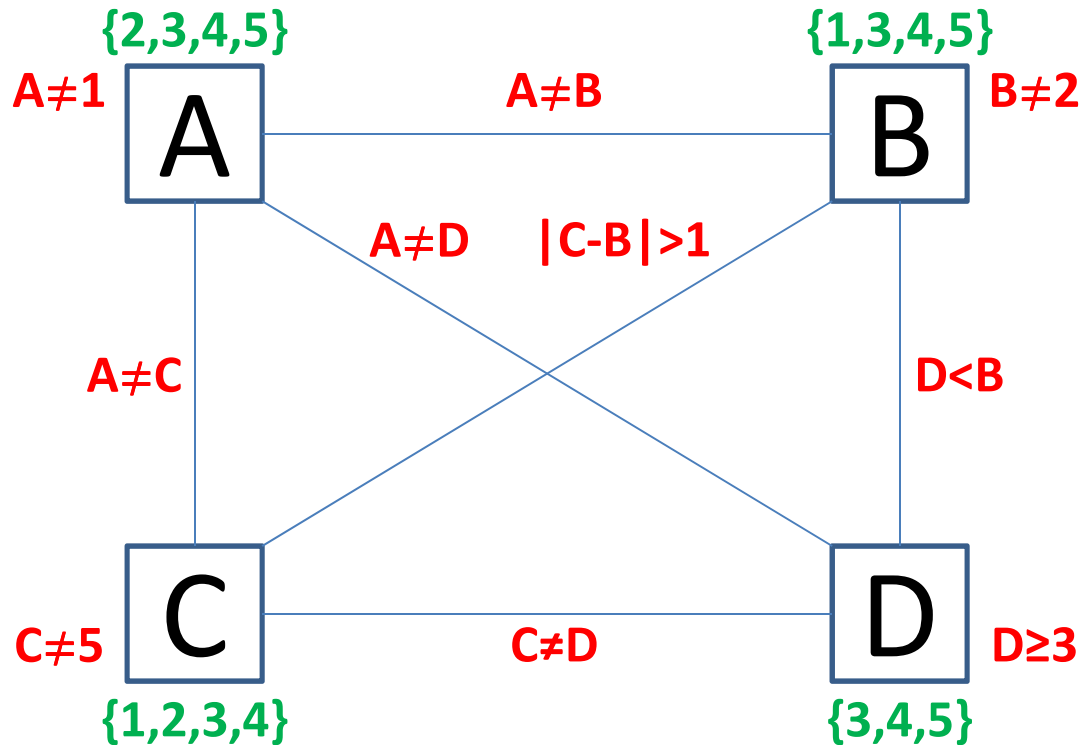

MiniMax & Constraint Processing: The 4 Houses problem

CONSTRAINT PROCESSING: FORWARD CHECKING

Forward Checking

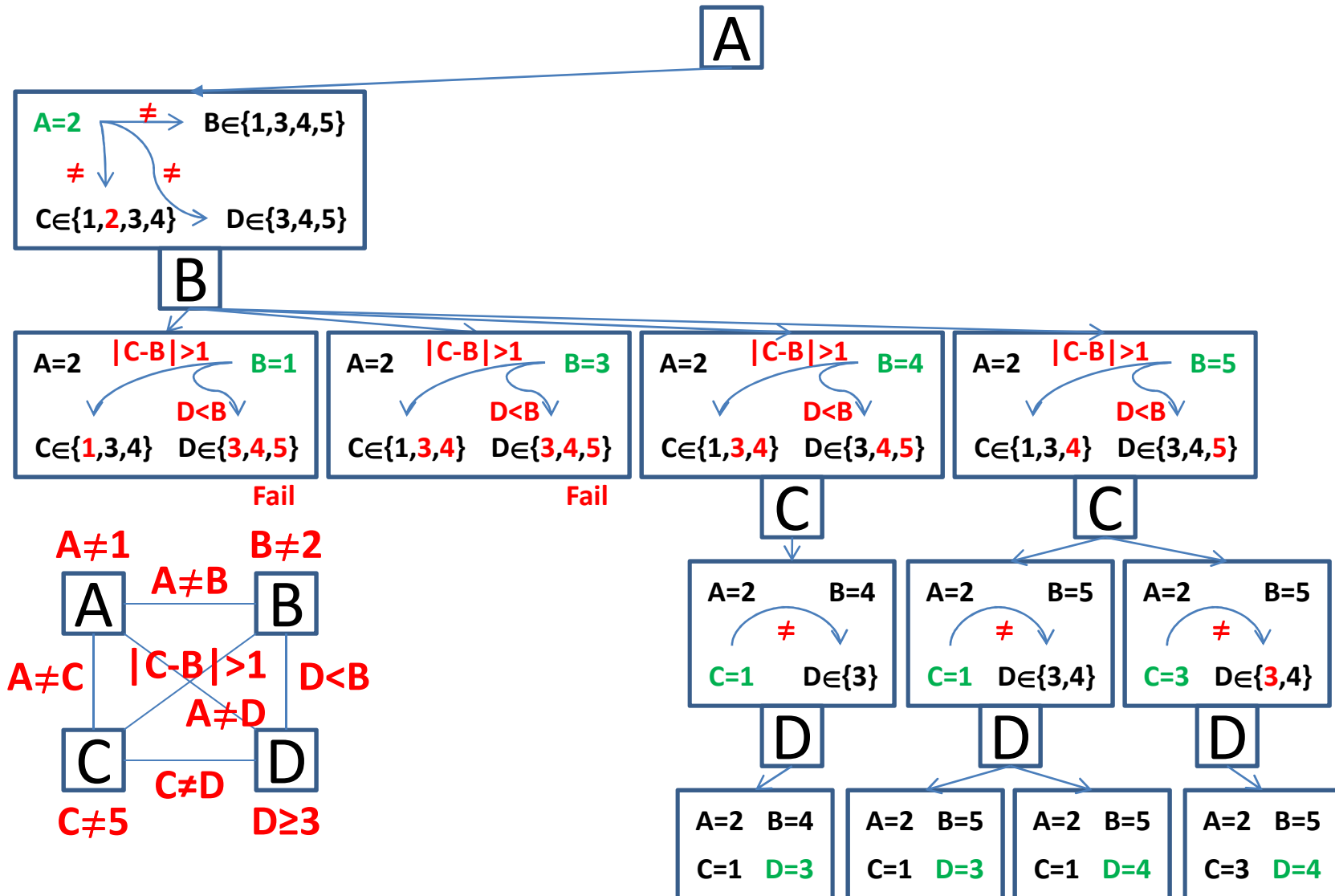

Forward Checking

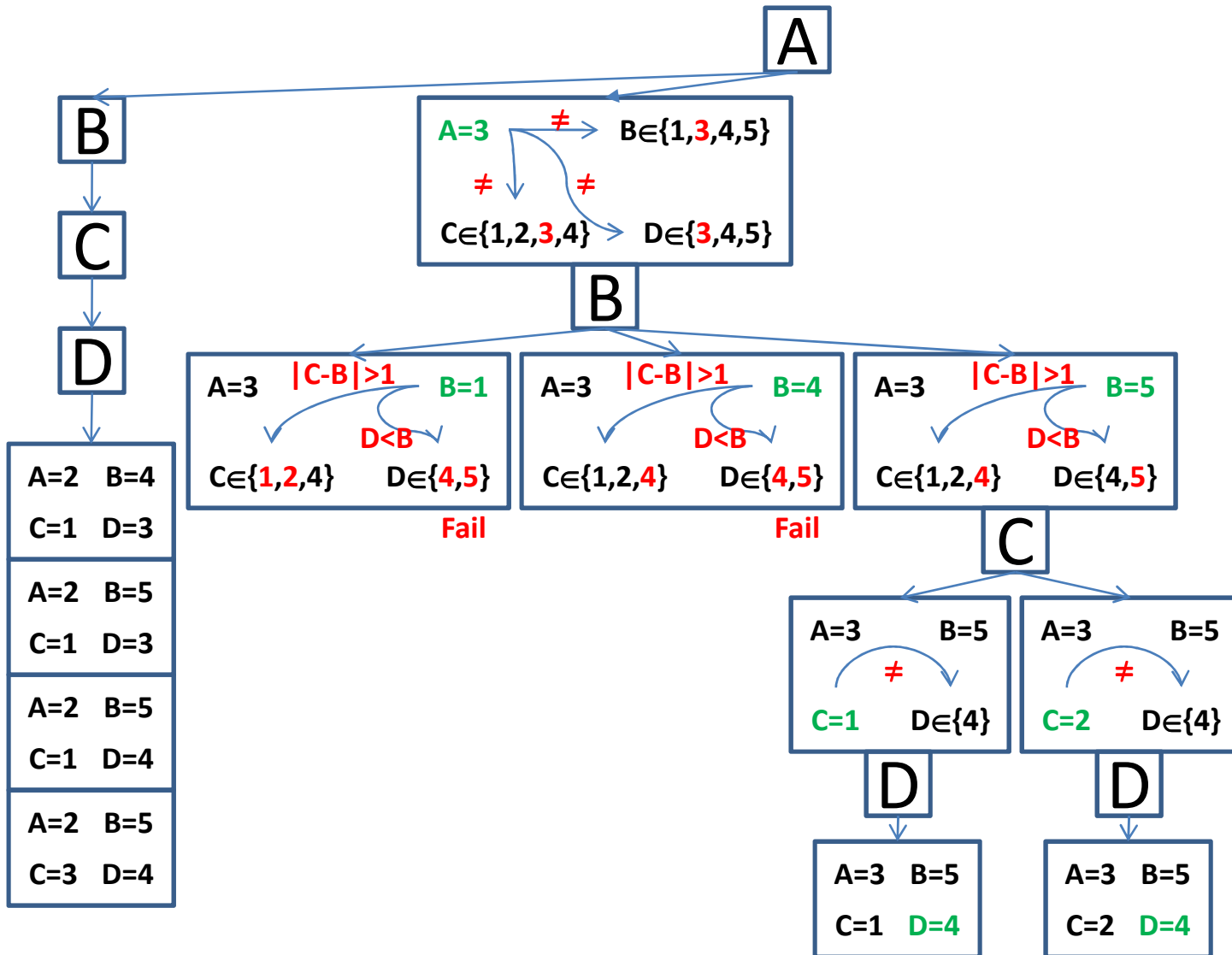

Forward Checking

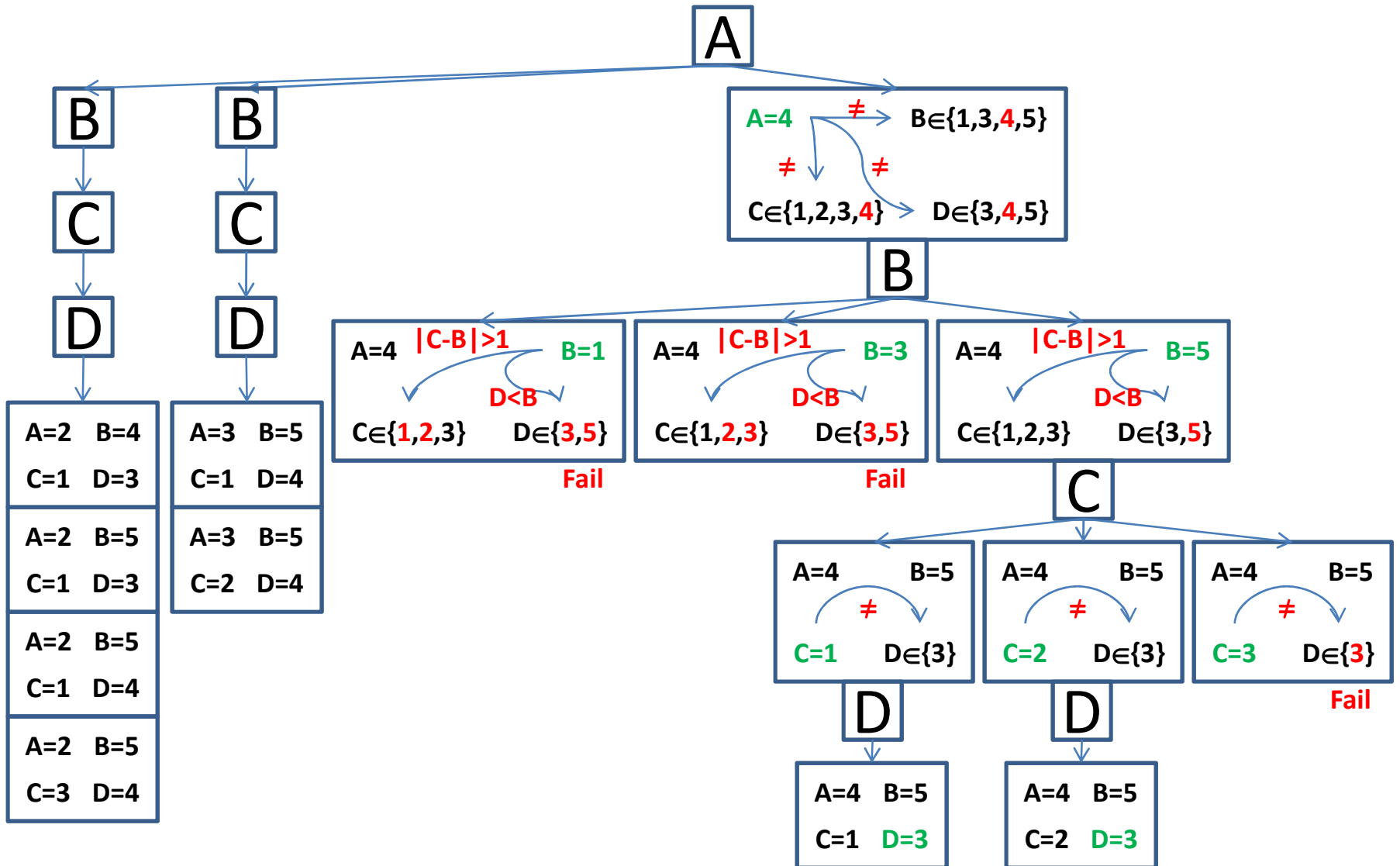

Forward Checking

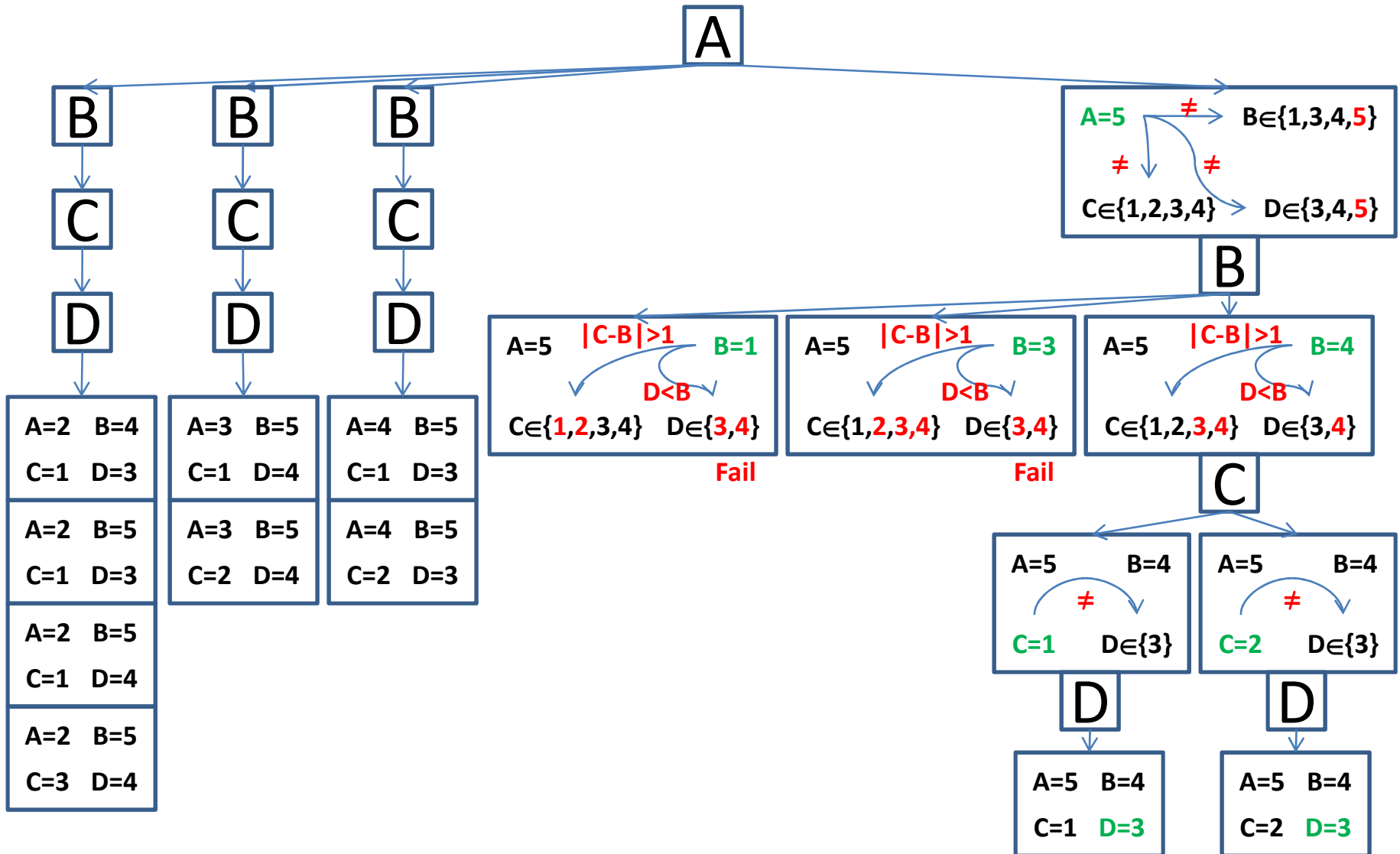

Forward Checking

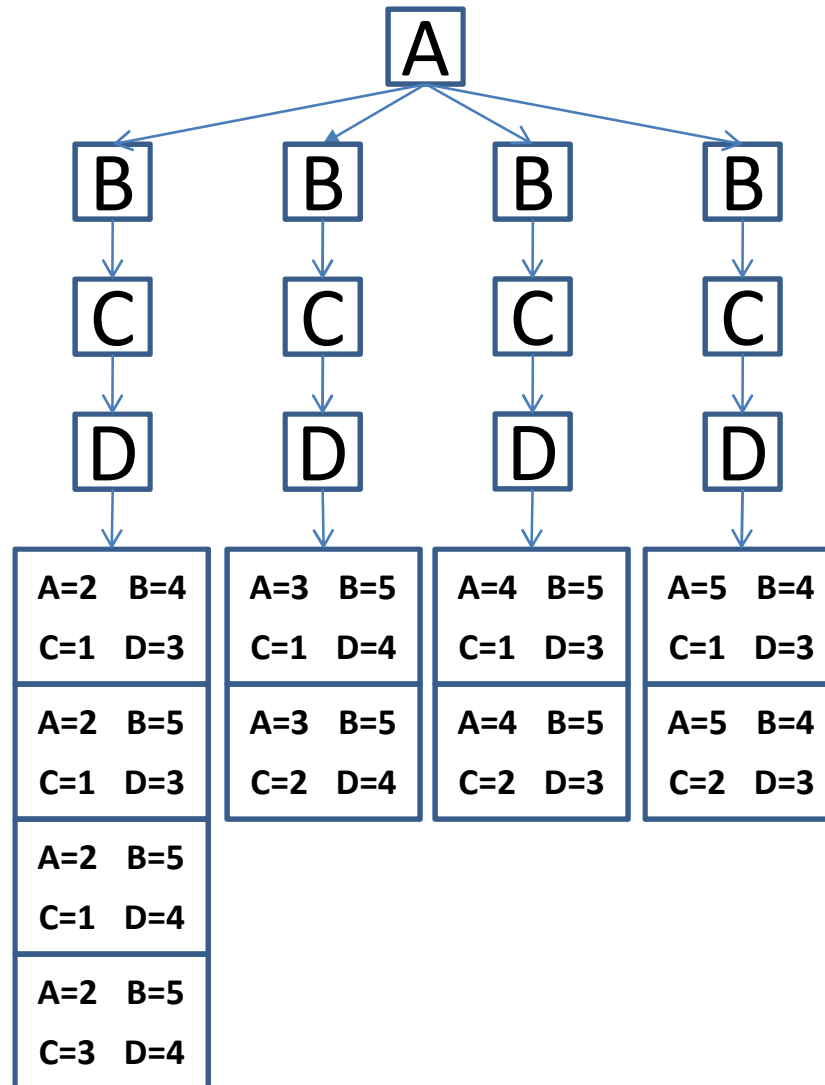

MiniMax & Constraint Processing: The 4 Houses problem

CONSTRAINT PROCESSING: DYNAMIC SEARCH REARRANGEMENT FC

Dynamic Search Rearrangement FC

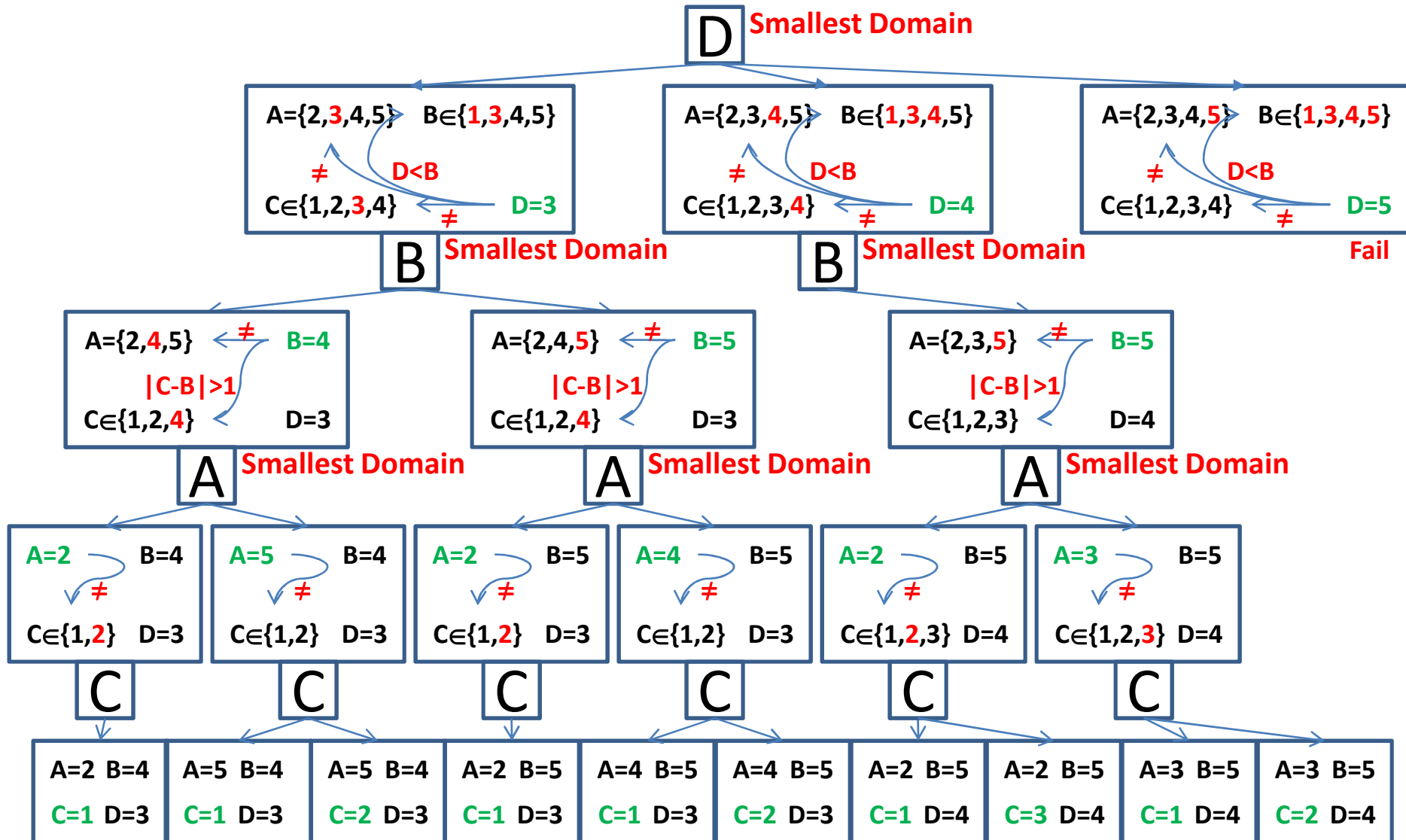

Exercises: Artificial Intelligence

Constraint Processing II & Waltz:
Waltz I

Solution

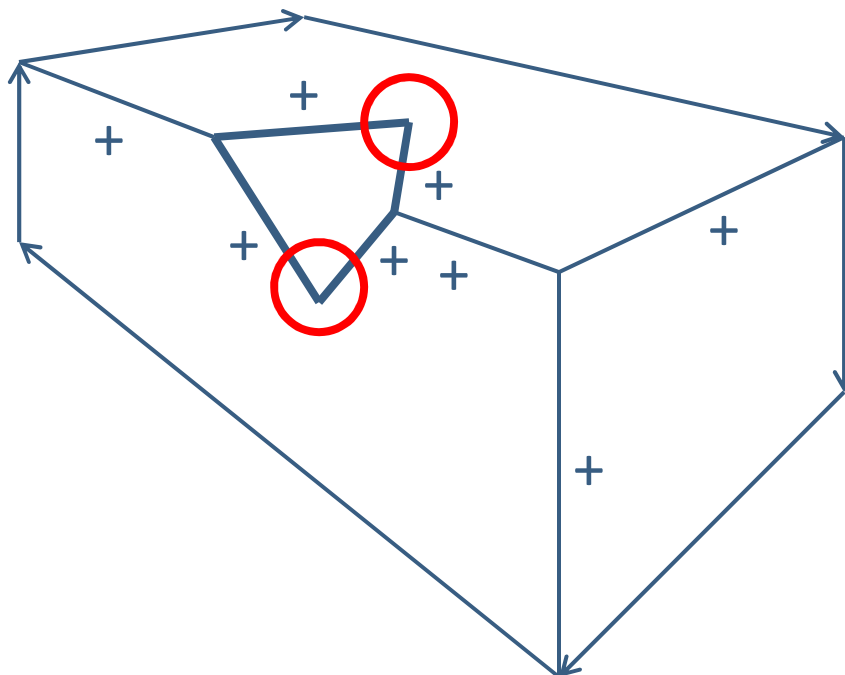

Solution

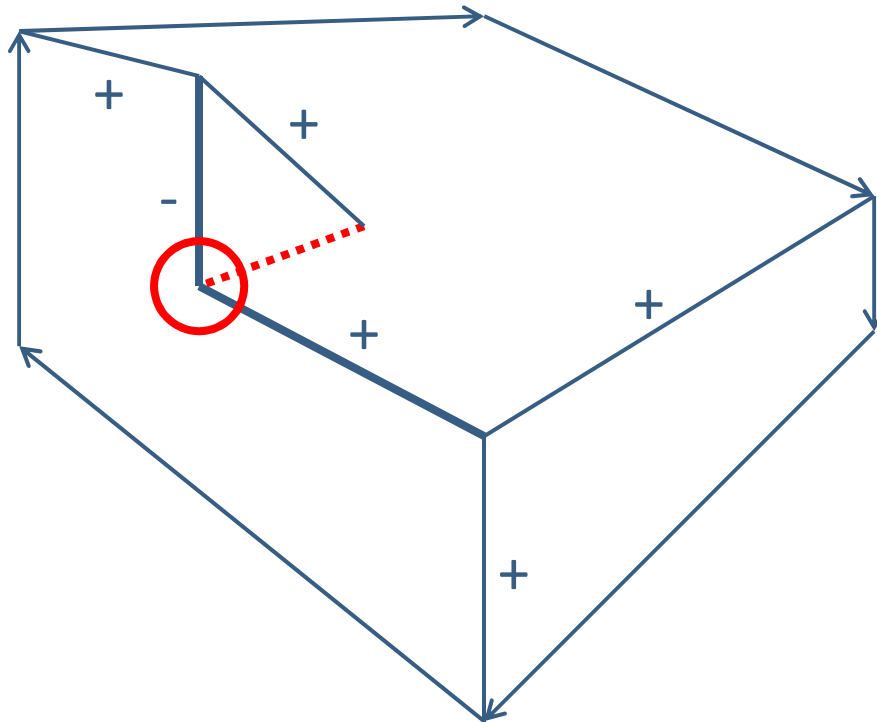

Solution

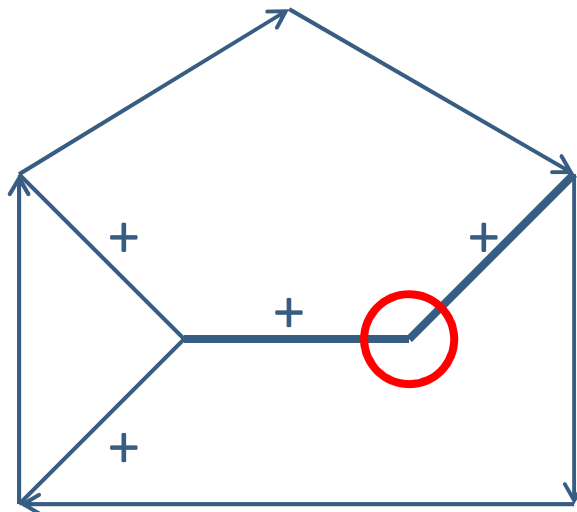

Solution

Line Drawing NOT allowed: 3-faced vertices!!

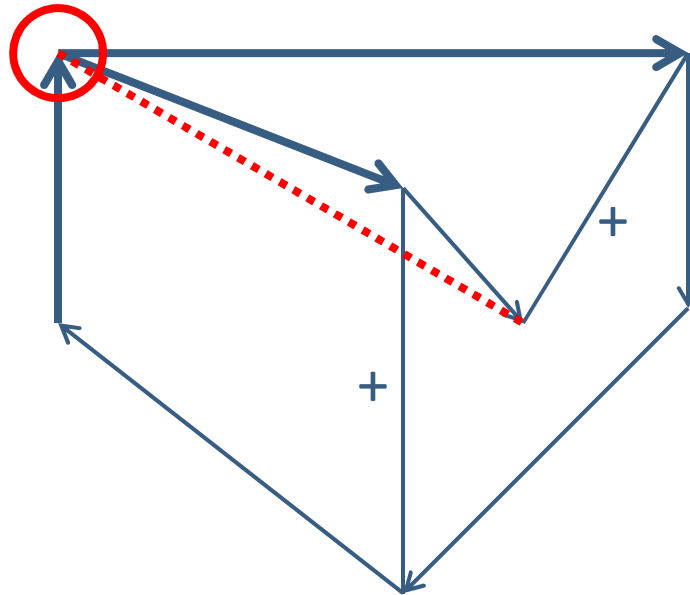

Solution

Drawing is locally correct, but is globally impossible.
Waltz procedure is local, thus, cannot detect this!

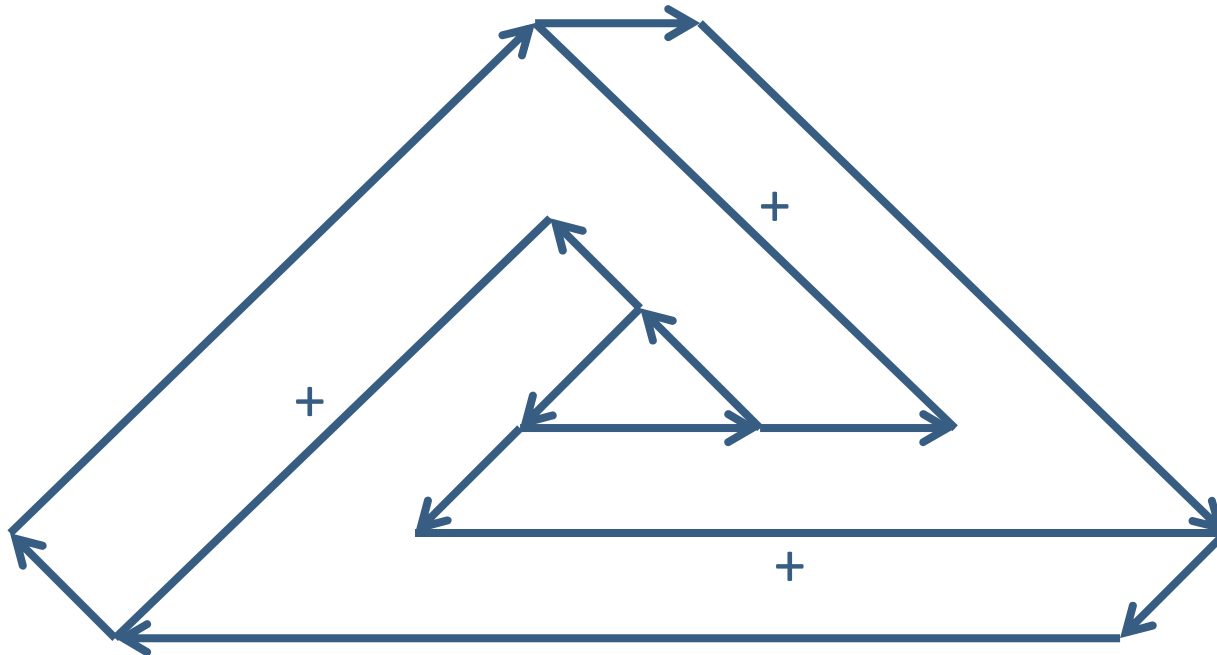

Exercises: Artificial Intelligence

Constraint Processing II & Waltz:
Waltz II

Solution

- Solution 2: Sitting cube

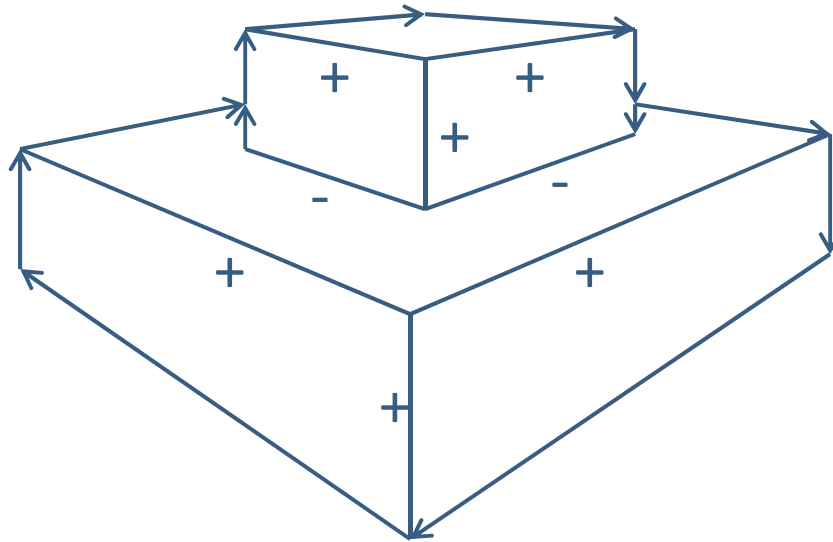

Exercises: Artificial Intelligence

Constraint Processing II & Waltz:
Waltz III

Solution

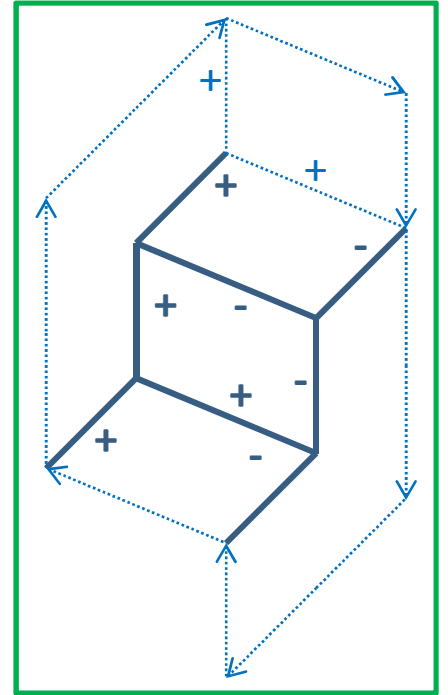
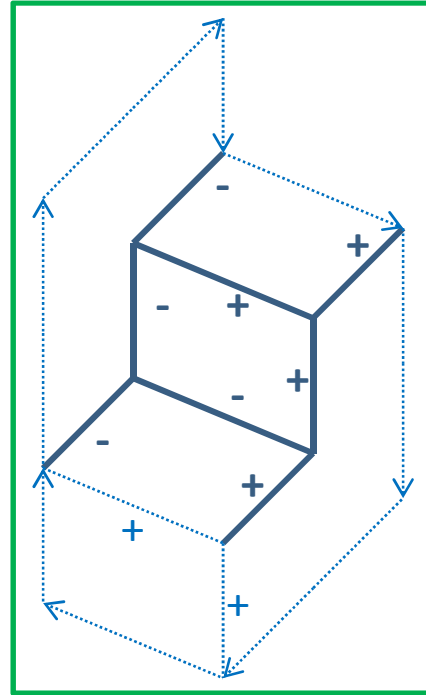
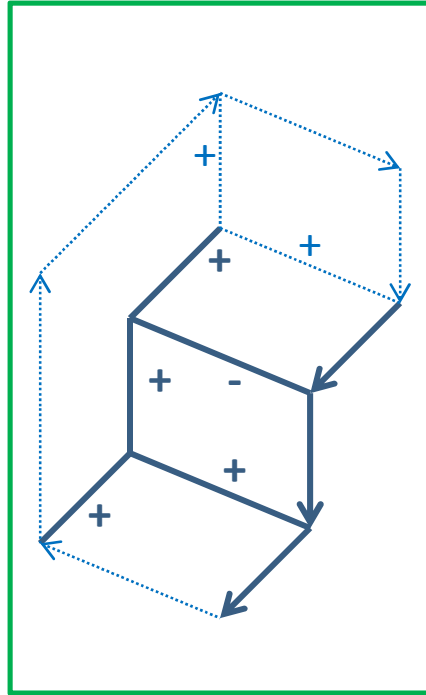
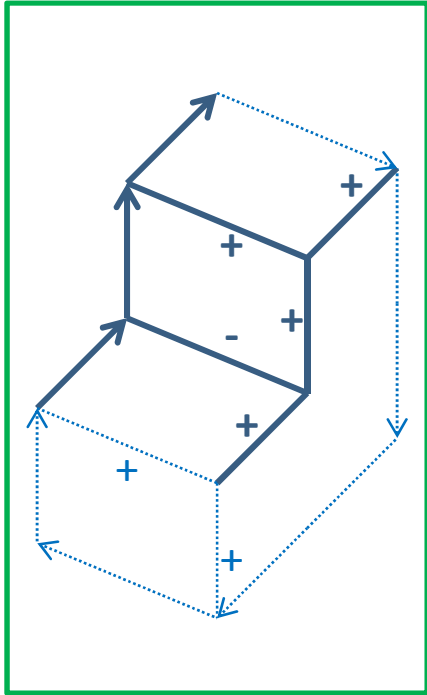

Exercises: Artificial Intelligence

Constraint Processing II & Waltz:
Waltz IV

Solution

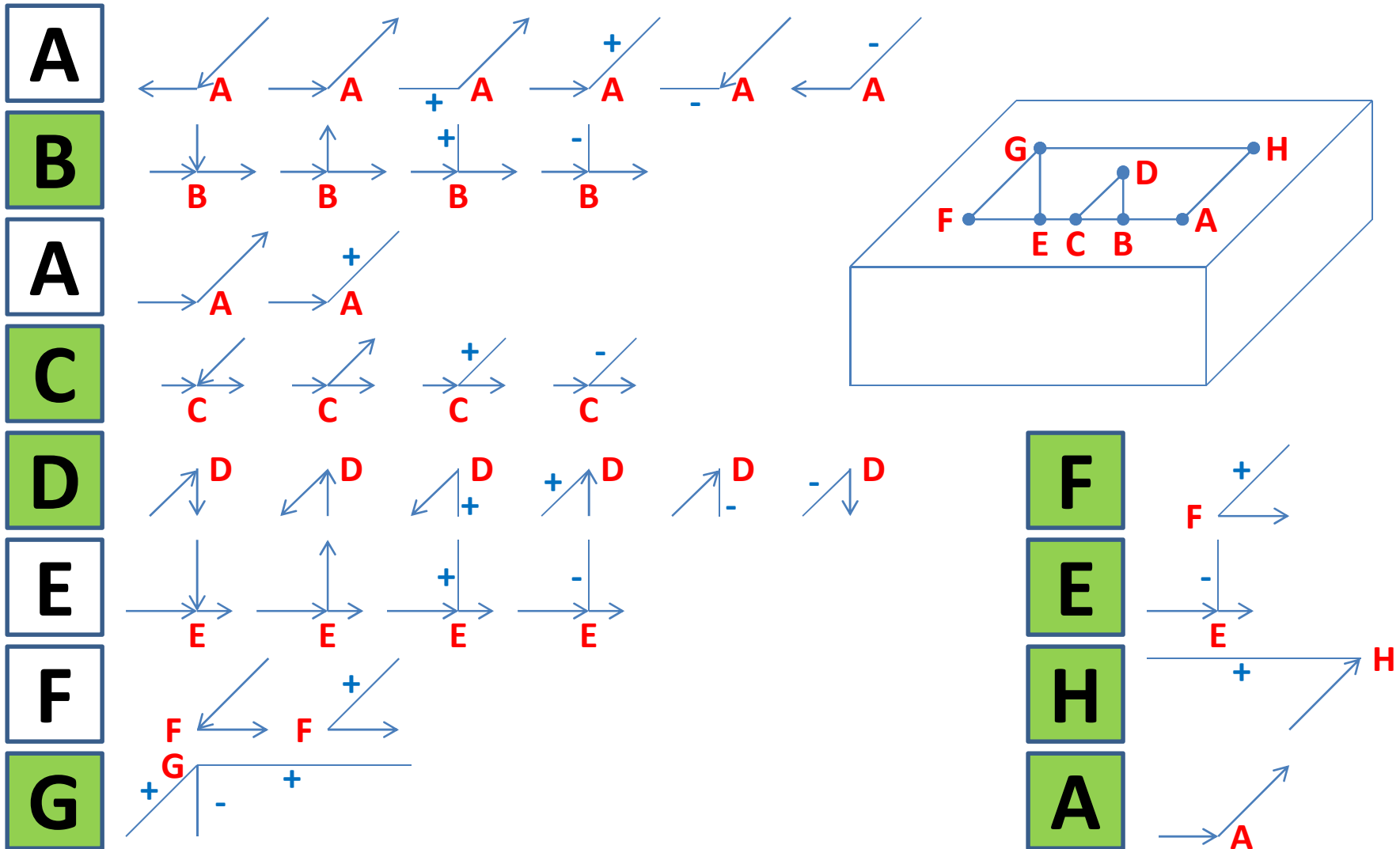

Solution

- We can determine **all nodes except for D**:

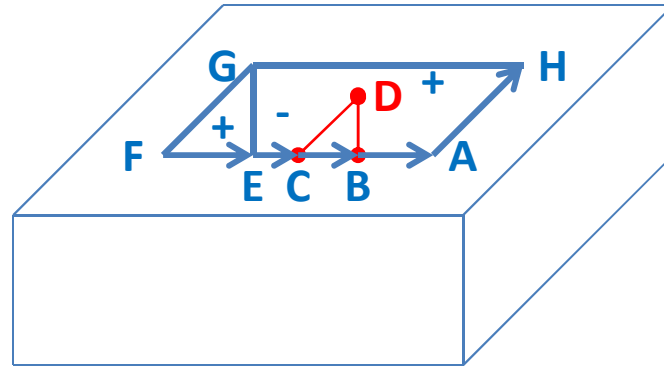

- **D** can still take **6 interpretations**:



Solution

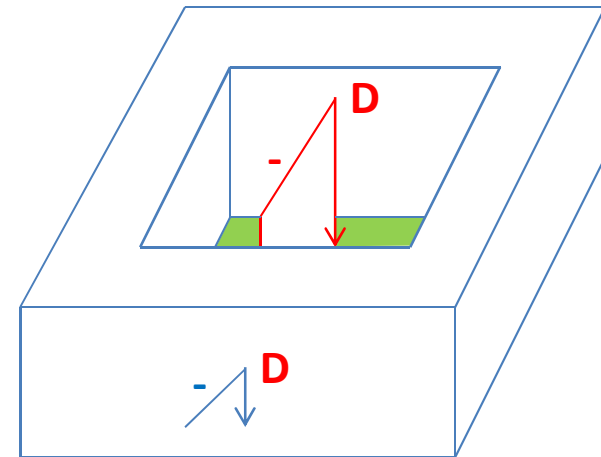
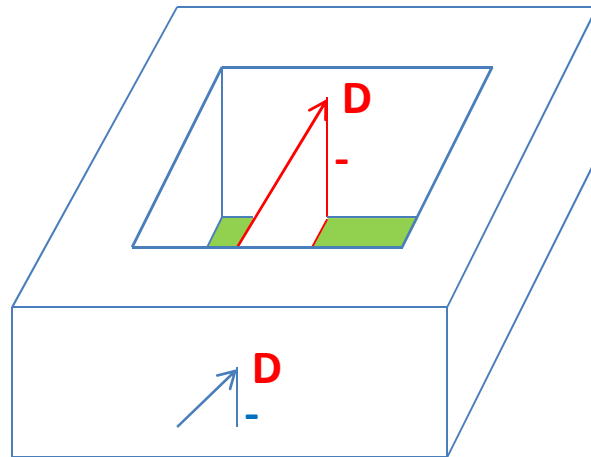
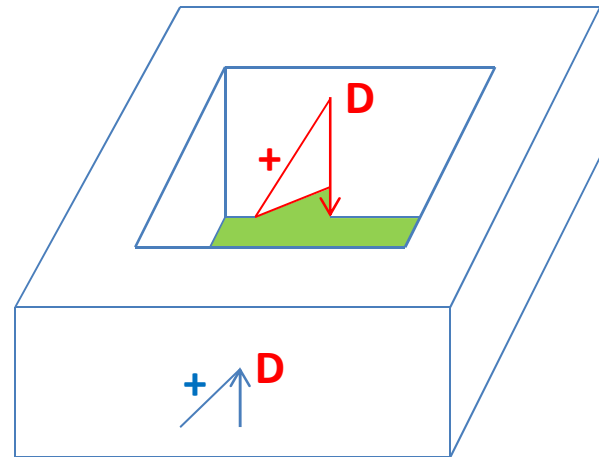
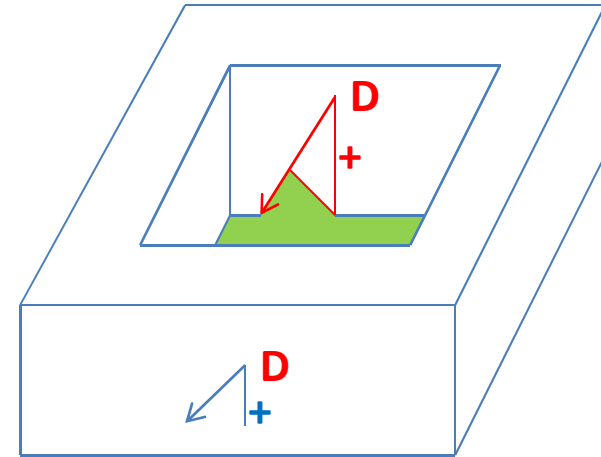
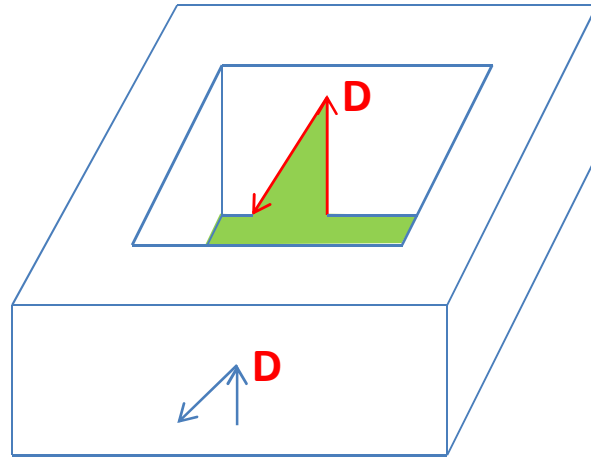
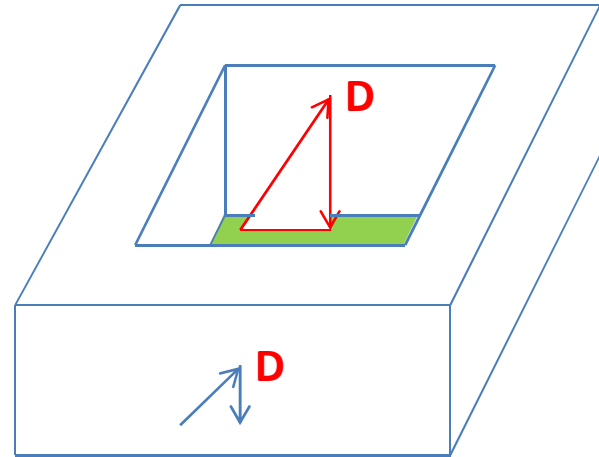

Exercises: Artificial Intelligence

Constraint Processing II & Waltz:
Waltz V

Termination Waltz

- ***Waltz's procedure terminates if***
 - No possibilities for some vertex **OR**
 - No reduction of junction piles
- ***Waltz's procedure does not terminate if***
 - Only non-empty piles **AND**
 - Reduction of piles possible
- **BUT**
 - Piles are finite \implies Number of iterations finite
 \implies **Waltz's procedure terminates**